

CONTOIL® VZD / VZP and DFM Consumption measurement

Applications

Fuel consumption measurement for trucks, buses, trains, construction and agricultural machinery, small boats and generators.



Features

- Quick and easy installation in vehicles of every type
- Supports most used models
- Short down-time (OFF-operation) period
- Proved and tested system
- Easy and accurate reading of engine fuel consumption
- No extra maintenance necessary
- Tamper-proof measurement

Your benefits

- Low installation costs
- Quick and easy installation
- Short down-time of vehicle
- Quick pay-back period

The right product for every application

Suitable for trucks, buses, agricultural and construction vehicles, small river boats

CONTOIL® VZD / VZP System



Flow meters for direct fuel measurement

Suitable for small engines

CONTOIL® VZD 4

The easy way to find your fuel consumption. Just install it and read the values on the display (total, trip, current consumption and more).

CONTOIL® VZP 4

If the installation place is hidden and a read-out on the flow meter not possible, than this flow meter is the right one. Connect it to the CONTOIL® VZD CU and you will have all the necessary information wherever you want it.

Suitable for large engines

CONTOIL® VZD 8

An easy way to find your fuel consumption. At a glance, you have the following information: total, trip, actual fuel consumption and much more. With its digital output, the results can be transferred to a remote host.

CONTOIL® VZP 8

For installation places where the read-out is not easy, choose this flow. The build-in LED gives you the function status at any time. The VZD CU is recommended for fuel calculation. Connection to a remote calculator is possible (eg. fleet manager).

Suitable for remote control

CONTOIL® VZD CU

Remote calculator for the VZD/VZP series. Install the VZD Control Unit in the driver cabin and you have all the necessary information about fuel consumption every time. Flow meters from competitors can be connected.

**CONTOIL®
DFM System**



**CONTOIL®
DFM 8EDM**



Flow meters for differential fuel measurement

Suitable for small engines

CONTOIL® DFM 8D

- Compact 2-chamber system
- Space-saving design
- Built for extreme environments

CONTOIL® DFM 8S

- Compact 1-chamber system (2 pieces needed for differential measurement)
- Designed for engines where the supply line and return line are some distance from each other
- Built for extreme environments

Suitable for large engines

CONTOIL® DFM 20S / CONTOIL® DFM 25S

- Compact 1-chamber system (2 pieces needed for differential measurement)
- Built for extreme environments
- Suitable for big agricultural and construction vehicles, big river boats, small vessels

Suitable for calculation and data-sending to remote

CONTOIL® DFM-BC (board computer)

- Suitable for all DFM flow meters and other manufacturers' flow meters
- Total, trip, current consumption, info, service (password-protected)
- Configurable input-pulse value (0.1 ml to 9.9 litre)

Page 8

Flow meter for fleet manager DFM System

CONTOIL® DFM 8EDM

Easy-to-install flow meter – just connect the pipes and the three electrical wires. The calculated consumption will be sent as a passive pulse and a TTL pulse

Page 12

Additional information

Page 14

Your savings

Page 16

How to measure fuel

Two systems are on the market...

- **Direct consumption**

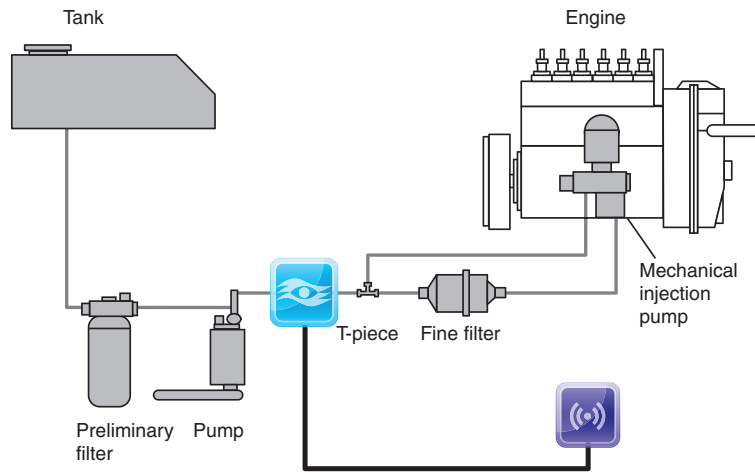

With this variant, the fuel is sucked out of the tank by the pump and through the preliminary filter, then fed through the fine filter to the mechanical injection pump. Depending on the engine conditions, the injection pump measures the fuel to be injected and forwards it to the individual cylinders. There, the fuel is injected into the combustion chamber by the injection nozzles. The pump's job is to provide 4 to 10 times the amount of fuel that could possibly be used (e.g. for a maximum consumption of 50 l/h, the pump should be able to supply 200 l/h to 500 l/h). This quantity depends on the engine and the manufacturer; the above figures are just guidelines. The unused fuel is returned back to the tank through a separate line. This is the standard in modern engines (common rail, etc.).

- **Differential consumption**

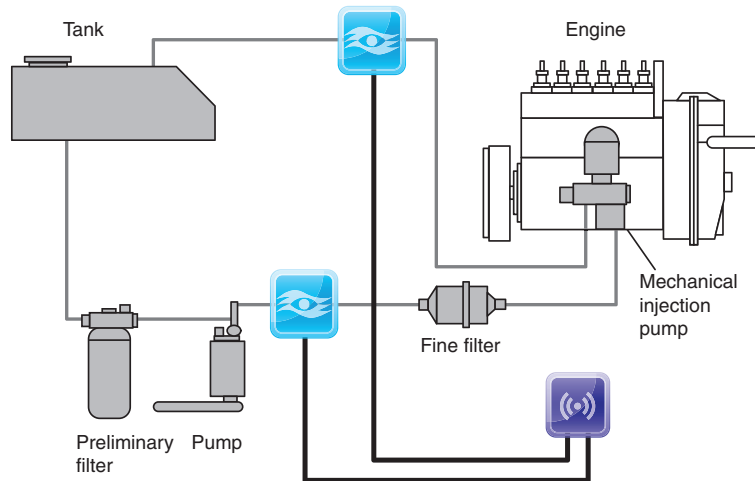

With this variant, the fuel is sucked out of the tank by the pump and through the preliminary filter, then fed through the fine filter to the mechanical injection pump. Depending on the engine conditions, the injection pump measures the fuel to be injected and forwards it to the individual cylinders. There, the fuel is injected into the combustion chamber by the injection nozzles. The unused fuel is not fed back to the tank through a separate line, but is fed back into the fuel line after the pump and before the fine filter in order to filter out any mechanical impurities. In this variant, the pump supplies the amount of fuel required by the engine, depending on its operating mode. The pump supply is controlled by the pressure after the pump.

... and we offer and support both of them.

CONTOIL® VZD/VZP System

CONTOIL® VZD with digital display shows you all information at a glance



- Total fuel consumption (litre, gal. or kg/m3)
- Correction factor (eg. temperature compensation)
- Daily fuel consumption (litre, gal. or kg/m3)
- Idle time of the engine
- Current consumption (litre, gal. or kg/m3)
- Working time of the engine
- Fuel temperature
- CO₂ measurement (actual and total)

Technical data

- Safety
Tested for vibration, shock and electrical emission and immission (vehicle industry standards)
- Operation temperature of the hydraulic: -30°C to +80°C
- Diesel fuel, domestic fuel oil, engine oil (viscosity max. 6 cSt)

VZ0 4 and 8 with directive 2004/22/CE (MID)

Device	VZD 4	VZP 4	VZD 8	VZP 8	VZD CU
Part number	94679	94681	94680	94682	94706
Hydraulic connection	M14x1.5	M14x1.5	M14x1.5	M14x1.5	n.a.
Nominal pressure	25	25	25	25	n.a.
Temperature display (°C)	-20 to +60	n.a.	-20 to +60	n.a.	-20 to +60
Protection class (IP)	66	66	66	66	66
Max. flow rate (l/h) 1)	80	80	200	200	n.a.
Nominal flow rate (l/h)	50	50	135	135	n.a.
Min. flow rate (l/h)	1	1	4	4	n.a.
Accuracy (%) better than	1	1	1	1	n.a.
Repeatability (%)	+/- 0.2	+/- 0.2	+/- 0.2	+/- 0.2	n.a.
Registration capacity	999999.99	n.a.	999999.99	n.a.	999999.99
Safety filter mesh size (mm)	0.125	0.125	0.150	0.150	n.a.
Volume of measuring chamber (ml)	5.0	5.0	12.5	12.5	n.a.
Battery	Yes	No	Yes	No	Yes

Electrical specifications

Device	VZD 4	VZP 4	VZD 8	VZP 8	VZD CU
Max. frequency of input-pulse	n.a.	n.a.	n.a.	n.a.	13Hz
Pulse OUT (HI-Res) width	20ms	20ms	20ms	20ms	n.a.
Pulse OUT (Param) width	1000ms	n.a.	1000ms	n.a.	1000ms
Current load (open drain output) max.	50mA	50mA	50mA	50mA	50mA
Output operational voltage max.	48VDC	48VDC	48VDC	48VDC	48VDC

n.a. = not available

CONTOIL® VZP 4/8

Remote-Device
e. g. fleetmanager

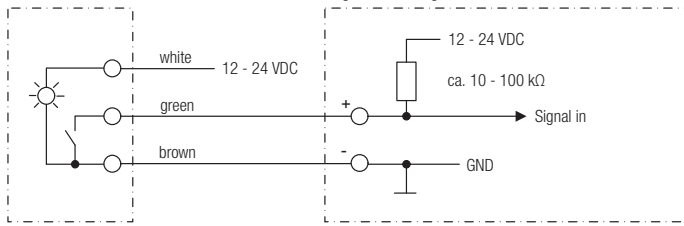

CONTOIL® VZD 4/8

Remote-Device
e. g. fleetmanager

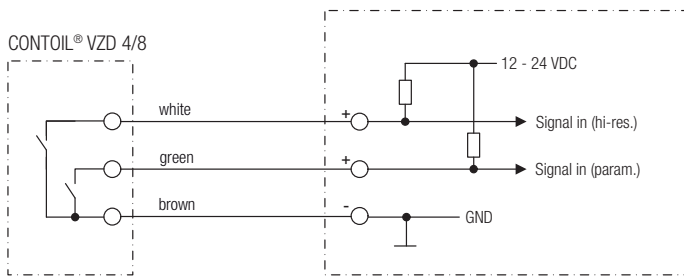

Short view of the CONTOIL® VZD 4 and VZD 8 menu

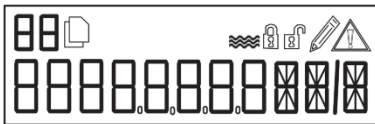

Main menu

- Total, trip, current consumption
- Info, service
- Logger data, error data, display test

Info/service menu

- Idle/working mode, operation hours, unit
- Battery capacity, fuel temperature, RESET mode
- Correction factor, password
- Current CO2 emission, total CO2 emission
- Min. flow rate, max. flow rate
- Date, time

The complete menu is shown in the Operating Manual

Materials

Table of materials used

Parts	Materials
Housing/measuring unit	Brass
Seals	NBR butadiene-acrylonitril
Rotary piston	Anodised aluminium

Dimensions

CONTOIL® VZD 4 und VZP 4

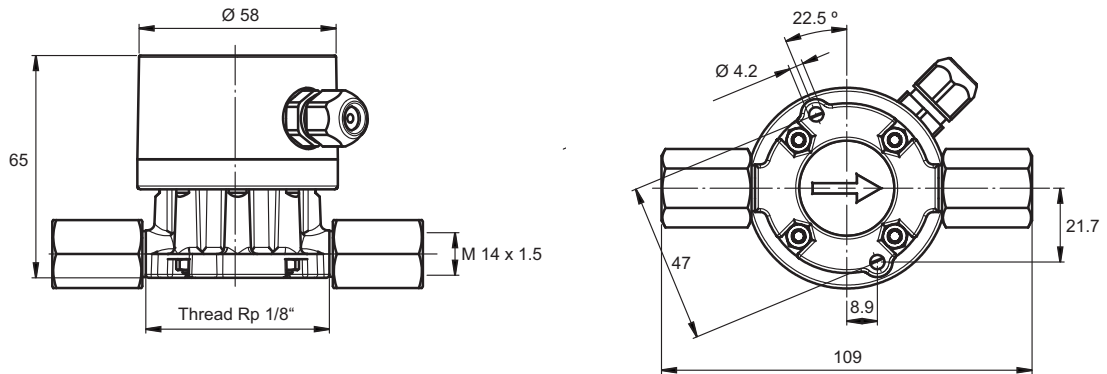

CONTOIL® VZD 8 und VZP 8

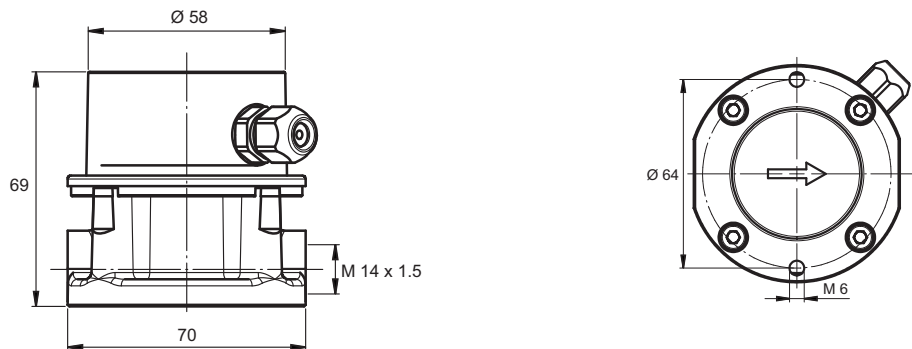

CONTOIL® VZD CU



Accessories

Table of materials used

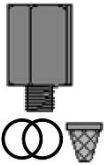
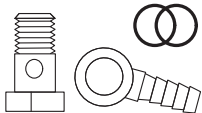
	Description		Quantity	Part number
	Gasket for VZD/VZP 4	FKM	1	19912
	Gasket for VZD/VZP 8	FKM	1	11357
	Modification kit	VSR-SET VZD/VZP 4 1/8" to M14x1.5	1 *)	80630
	Threaded connections	PS-Satz DFM and VZD/VZP	1 *)	80447

*) 2 sets needed for one flow meter.

CONTOIL® DFM System

With the DFM-BC (board computer), you have all the information at a glance



- Total fuel consumption
- Daily fuel consumption
- Current consumption
- Info mode
- Service mode
- Status of the supply or return line
- Correction factor (eg. temperature compensation)
- Configuration log
- Error log

Technical data

- Safety
Tested for vibration, shock and electrical emission and immission (vehicle industry standards)
- Operation temperature of the hydraulic: -30°C to +80°C
- Diesel fuel, domestic fuel oil, engine oil (viscosity max. 6 cSt)

Hydraulic specifications

Device	DFM 8D	DFM 8S	DFM 20S	DFM 25S
Part number 94465	94464	94466	94467	
Hydraulic connection	M14x1.5	M14x1.5	G1"	G1 ¼ "
Nominal pressure	16	16	16	16
Temperature (°C)	-30 to +80	-30 to +80	-30 to +80	-30 to +80
Temperature display (°C)	-20 to +60	-20 to +60	-20 to +60	-20 to +60
Protection class (IP)	66	66	66	66
Nominal flow rate (l/h)	200	200	1000	2000
Min. flow rate (l/h)	10	10	100	200
Accuracy (%) better than	1	1	n.a.	1
Repeatability (%)	+/- 0.2	+/- 0.2	n.a.	+/- 0.2
Safety filter mesh size (mm)	N.A	N.A	0.400	0.400
Volume of measuring chamber (ml)	12.5	12.5	36	100

Electrical specifications

Flow sensor	l/pulse (ml/pulse)	Hz (max.)	Pulse interval (min.)	Pulse width	mA (max.)	VDC (Nominal)
Double sensor DFM 8D	0.0125 (12.5)	15	46	20 ms	10	12-24
Single sensor DFM 8S	0.0125 (12.5)	15	46	20 ms	10	12-24
Single sensor DFM 20S	0.036 (36)	15	46	20 ms	10	12-24
Single sensor DFM 25S	0.100 (100)	15	46	20 ms	10	12-24

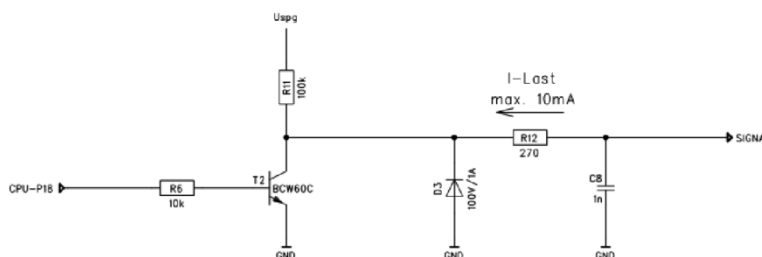

CONTOIL® DFM-BC specifications

- Safety
Tested for vibration, shock and electrical emission and immission (vehicle industry standards)
- Operation temperature of the hydraulic: -10°C to +70°C
- Diesel fuel, domestic fuel oil, engine oil (viscosity max. 6 cSt)
- 3" graphic display
- 4 navigation keys

Further specifications

Device	DFM-BC
Part number	94476
Registration (in litre)	100.000.000
Input (flow meter connections), adjustable from 0.1ml to 9999.9ml	2
Output (for remote device) adjustable from 0.1ml to 9999.9ml	1
Temperature (°C)	-10 to +70
Data storage	EEPROM
Online status of the connected flow meters	Yes
Protection class (IP)	IP66

Electrical specifications

Max. frequency of input/output pulses	25Hz.
Cable lengths	7.5m
Power supply (direct from the vehicle battery)	12VDC to 24VDC
Power supply cable	2x 0.75mm ²
Current load (pulse in/pulse out; open drain output) max.	15mA
Pulse width (pulse in/pulse out) min	20ms
Output operational voltage max.	48VDC

Materials

Table of materials used for the flow meters

Parts	Material	DFM 8D, DFM 8EDM, DFM 8S	DFM 20S, DFM 25S
Housing/measuring chamber	Brass	•	
	Cast brass		•
Measuring chamber	Cast brass		•
Seals	FPM fluorelastomer	•	•
Rotary piston	Anodised aluminium	•	•

Dimensions

CONTOIL® DFM-8S

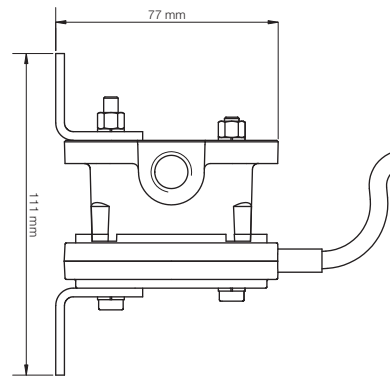
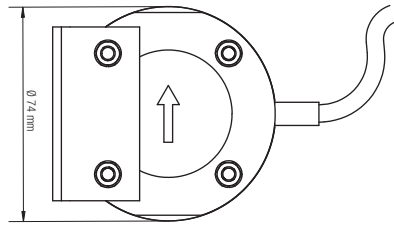

CONTOIL® DFM-8D

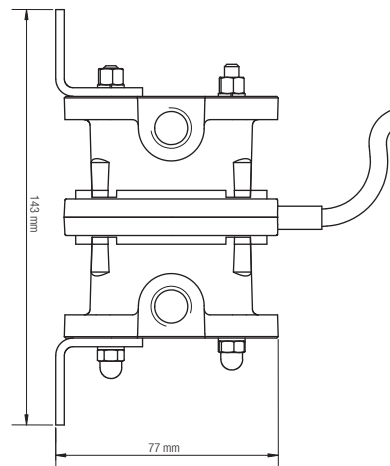
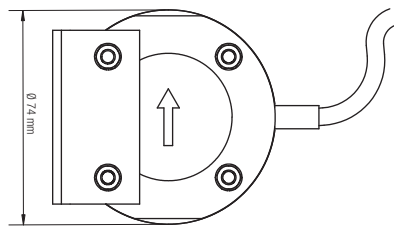

CONTOIL® DFM 20S and DFM 25S

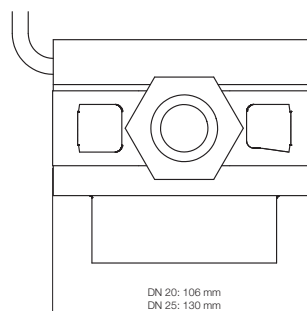
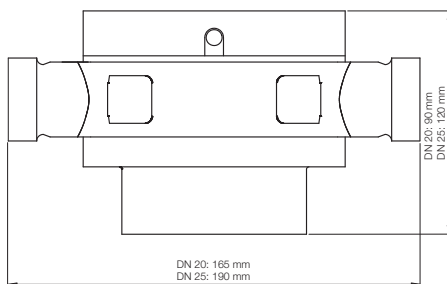

CONTOIL® DFM-BC

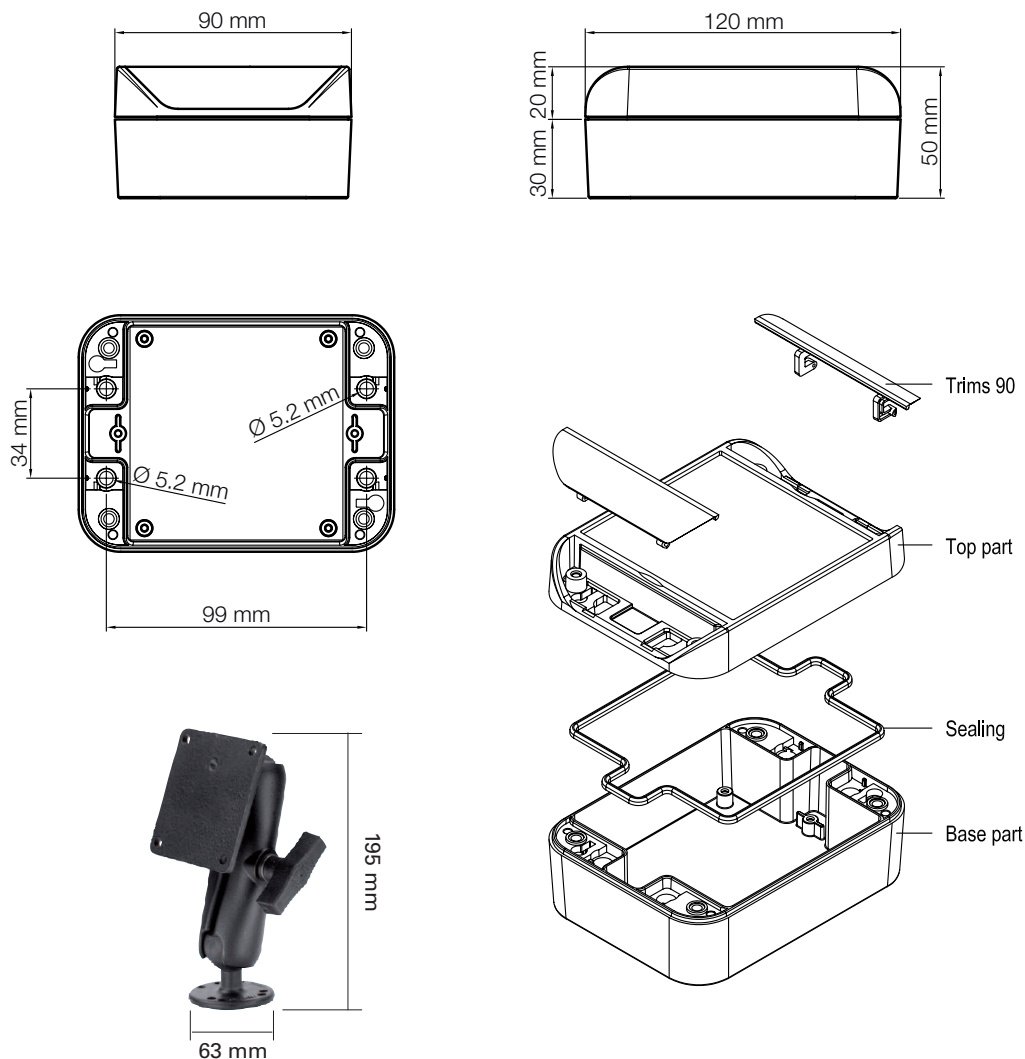

Accessories

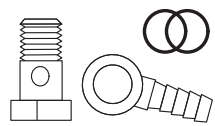
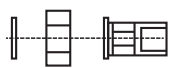
	Description		Quantity	Part number
	Mounting bracket DFM-BC	DFM-MB	1	80485
	Hose connector for DFM 8xxx include 1x hollow union, 1 single banjo body, 1x copper seal	DFM-8S/D	1 *)	80447
	Pipe connector for DFM 20S	VSR 3/4 "	1 **)	81166
	Pipe connector for DFM 25S	VSR 1 "	1 **)	81169

*) 2 sets needed for one DFM 8S.
 *) 4 sets needed for one DFM 8D
 **) 2 sets needed for one flow meter.

CONTOIL® DFM 8EDM

With integrated differential measurement



- Optimal design for fleet manager owner
- Integrated intelligence
- Passive pulse output
- TTL pulse output
- Compact 2-chamber system
- Space-saving design
- Built for extreme environments

Technical data

- Safety
Tested for vibration, shock and electrical emission and immission (vehicle industry standards)
- Operation temperature of the hydraulic: -30°C to +80°C
- Diesel fuel, domestic fuel oil, engine oil (viscosity max. 6 cSt)

Flow meter specifications

Device	DFM 8EDM
Part number	94954
Hydraulic connection	M14x1.5
Nominal pressure	16
Protection class (IP)	66
Nominal flow rate (l/h)	200
Min. flow rate (l/h)	10
Accuracy (%) better than	1
Repeatability (%)	+/- 0.2
Safety filter mesh size (mm)	N.A
Volume of measuring chamber (ml)	12.5

Electrical specifications

Flow sensor	l/pulse (ml/pulse)	Hz (max.)	Pulse interval (min.)	Pulse width	mA (max.)	VDC (Nominal)
Double sensor DFM 8EDM	0.0125 (12.5)	15	46	20 ms	10	12-24

Pulse specification

Passive Pulse

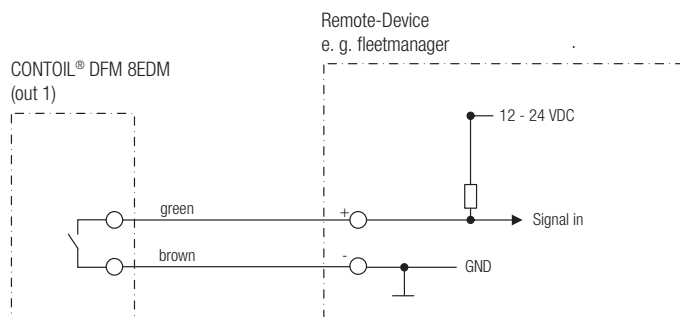

Whenever a pulse is generated, the electronic switch at the DFM 8EDM will be closed and the incoming 12-24VDC will be redirected to the external device.

TTL-Pulse

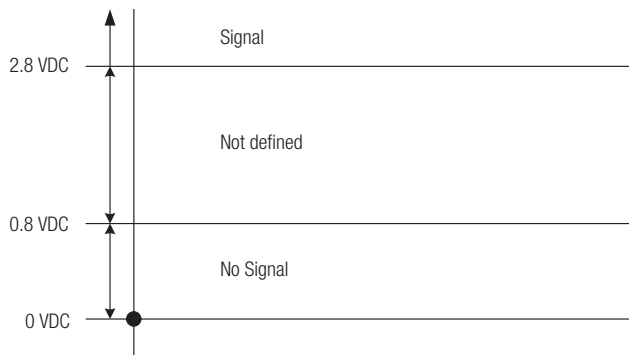

Below 0.8 VDC = no pulse (logic 0)
 Between 0.8 – 2.8 VDC is not defined
 Over 2.8 VDC = pulse (logic 1)

Materials

Table of materials used for the flow meters

Parts	Material
Housing/measuring chamber	Brass
Seals	FPM fluorelastomer
Rotary piston	Anodised aluminium

Dimensions

CONTOIL® DFM 8EDM

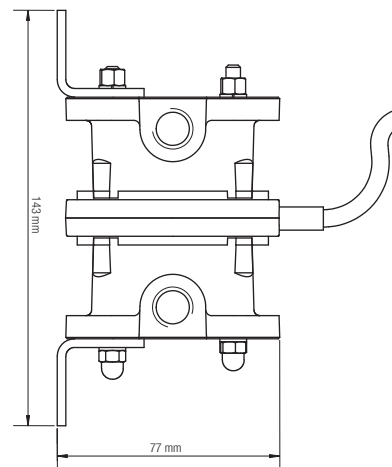
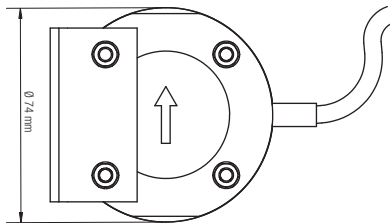

Accessories

	Description		Quantity	Part number
	Hose connector for DFM 8xxx include 1x hollow union, 1 single banjo body, 1x copper seal	DFM-8S/D	1 *)	80447

*) 4 sets needed for DFM 8EDM.

Additional Information

Fuel Oil

Our fuel flow meters are manufactured to run according to the fuel oil specification in the norm ISO 8217-2010. This norm specifies the characteristics of the fuel. Fuel oil with **low sulphur** can be used if it follows the rules specified in the mentioned norm.

A few parameters from this norm are listed in the table below.

Characteristics of different fuels

Fuel			Diesel *)	MGO 2 **)	MDO 2 **)
Density at 15°C	min.	Kg/l	0.820		
	max.	Kg/l	0.845		
Viscosity at 40°C		mPa.s	1.5 – 4.5	2-6	2-11
Lubricity value (HFRR)	max.	µm	470	520	520
Sulphur ***)	max.	%m/m		1.50	2.00

*) Diesel, diesel oil or AGO (Automotive GasOil) are the same

**) Also used for river boats

***)Max. value – normally, the value is much lower

Pressure drop curves

Viscosity information

Kinematic viscosity

Stokes, Centi-Stokes, mm²/s

St, cSt, mm²/s

Dynamic viscosity

Pascal seconds, millipascal seconds

Pas, mPa.s

Poise, Centipoise (outmoded)

P, cP

Conversion

cSt ÷ density = mPa.s

Engler degrees °E to mPa.s: only use conversion table

Saybolt units to mPa.s: only use conversion table

Redwood units to mPa.s: only use conversion table

Rule of thumb

1 cSt ~ 1 mm²/s ~ 1 mPa.s

CONTOIL® VZD 4, VZP 4

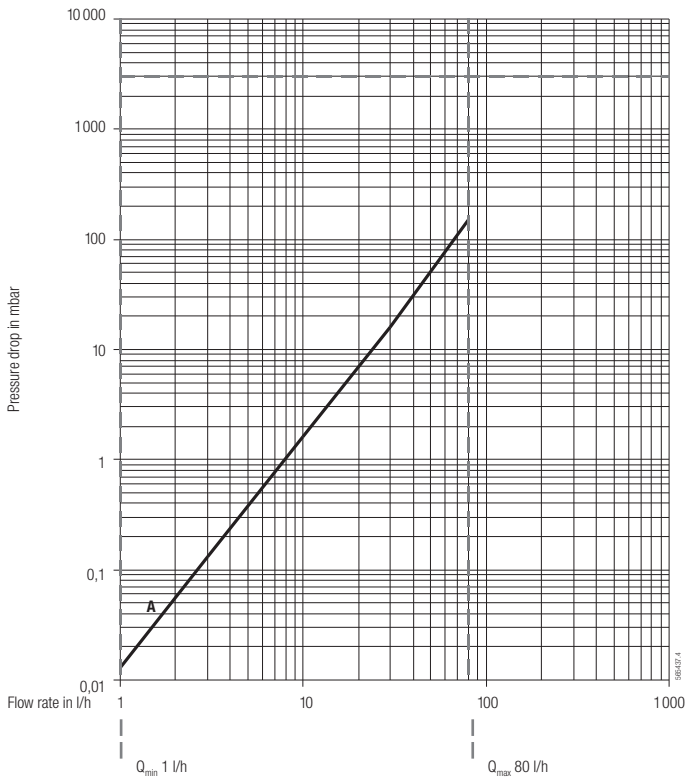

CONTOIL® VZD 8, VZP 8, DFM 8D, DFM 8S, DFM 8EDM

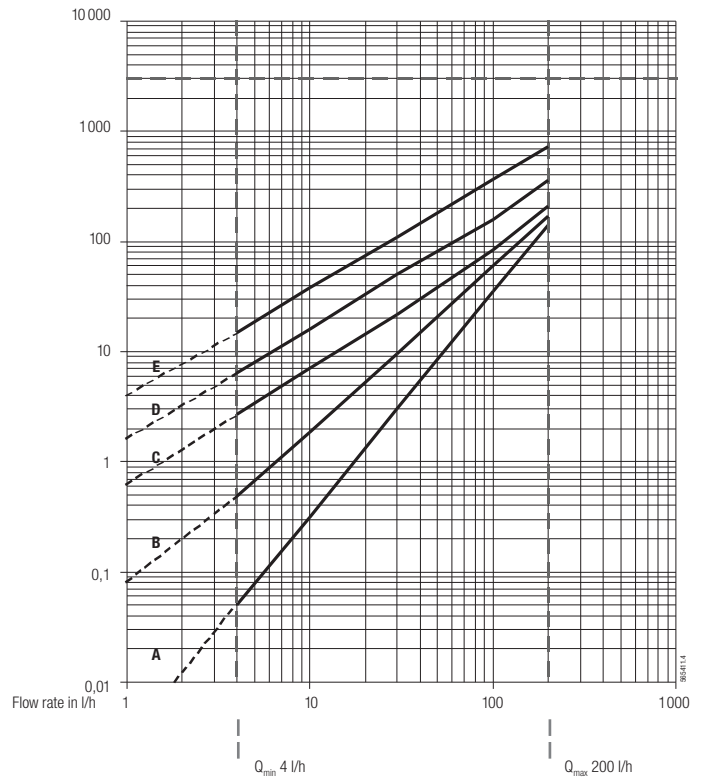

CONTOIL® DFM 20S

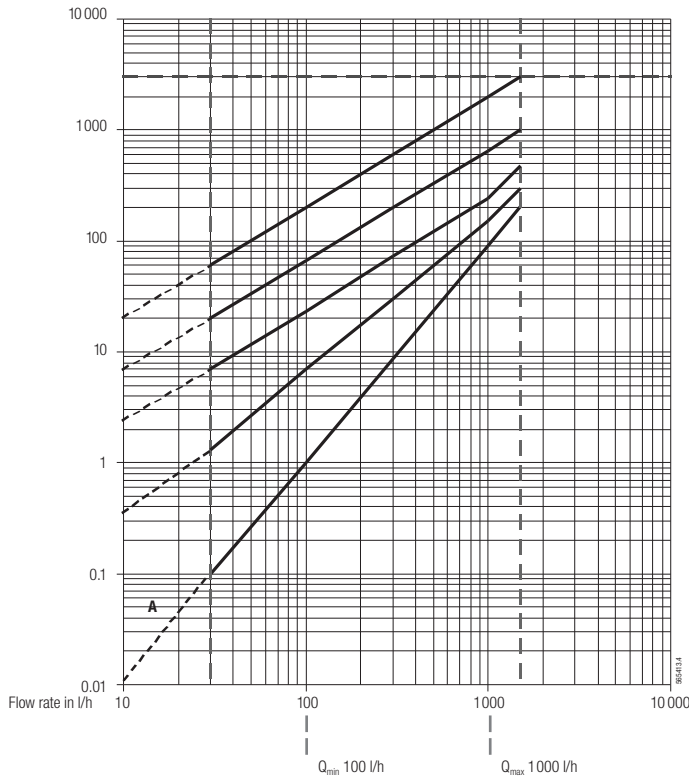

CONTOIL® DFM 25S

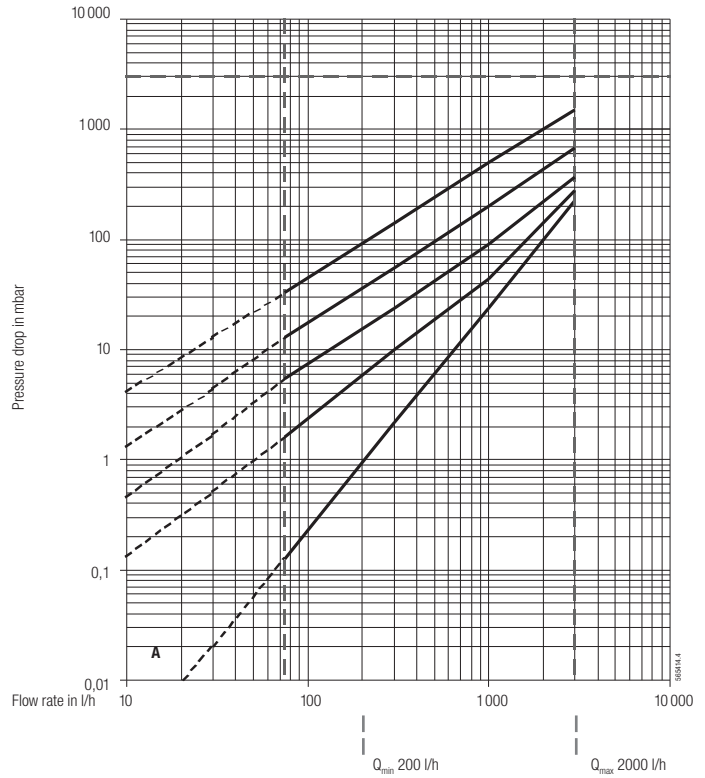

Viscosity diagrams:

A = 5 mPa.s
B = 50 mPa.s

C = 100 mPa.s
D = 200 mPa.s

E = 500 mPa.s

For a pressure drop of more than 1 bar, it is recommended to use the next larger meter size.
Maximum permissible pressure drop = 3 bar

Your savings

Example for trucks

Below are examples on how easy it is to calculate what this system is worth to you:

Operating data of vehicle (examples)

Km per day	200	200	500	750
Consumption in litres per 100 km	30	30	30	30
Operation days per year	250	250	250	250
Operation km per year	50'000	50'000	125'000	187'000
Operation days per year	15'000	15'000	37'500	56'250
Influence of fuel price				
Fuel price per litre in euros (assumption) ¹⁾	1.36	1.36	1.36	1.36
Fuel cost per year in euros	20'400	20'400	51'000	76'500
Return on Investment				
Complete investment cost in euros (example) ²⁾	1'400	1'400	1'400	1'400
Estimated reduction of fuel cost in %	20	15	10	5
Savings of fuel cost per year in euros	4'080	3'060	5'100	3'825
Pay-back time in months	4	5	3	4
Money saved in the first 12 months	2'680	1'660	3'700	2'425

1) Average price of diesel fuel in Europe

2) DFM 8D used for this example. Complete investment cost may vary from country to country due to local situations.
Includes flow sensors, board computer, all transport and import costs, installation and start-up of system.

Take the example from the third column: with the above vehicle operating data and 10% estimated reduction of fuel cost, the investment will pay back its costs after only three months. Since the figures are different in each area, they have to be adapted to individual values. Ask your authorised dealer for a personal assessment. He will calculate your possible cost savings based on your vehicle data, operating conditions and the local cost situation.

SALES PARTNER:

HEAD OFFICE:

AQUAMETRO AG
Ringstrasse 75
CH-4106 Therwil
Phone +41 61 725 11 22
Fax +41 61 725 15 95
info@aquametro.com



www.aquametro.com