



FULL FLOW GAS BALL VALVES: LONDON

069 London ball valve, full flow

LONDON
EN331 APPROVED (up to 2").



SIZE	PRESSURE	CODE	PACKING
1/4" (DN 8)	5bar/72.5psi	069B014	15/165
3/8" (DN 10)	5bar/72.5psi	069B038	15/165
1/2" (DN 15)	5bar/72.5psi	069B012	10/130
3/4" (DN 20)	5bar/72.5psi	069B034	8/64
1" (DN 25)	5bar/72.5psi	069B100	6/48

CERTIFICATIONS

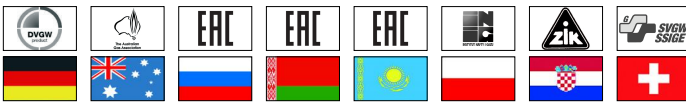

TECHNICAL SPECIFICATIONS

Female/female or male/female threads.

Body in nickel-plated brass.

Lever handle in steel (aluminium in the sizes 2"1/2, 3" and 4") or T handle in aluminium or flat lever handle in lined steel.

Minimum and maximum working temperatures: -20°C, 60°C.

Female threads:

- ISO 7/1 Rp parallel (equivalent to DIN EN 10226-1 and BS EN 10226-1) sizes 1/4" through 2".
- ISO228 (equivalent to DIN EN ISO 228 and BS EN ISO 228) sizes 2"1/2, 3" and 4"

Male threads:

- ISO 7/1 R taper (equivalent to DIN EN 10226-1 and BS EN 10226-1) sizes 1/4" through 2".
- ISO228 (equivalent to DIN EN ISO 228 and BS EN ISO 228) sizes 2"1/2, 3" and 4"



FULL FLOW GAS BALL VALVES: LONDON

OVERALL DIMENSIONS

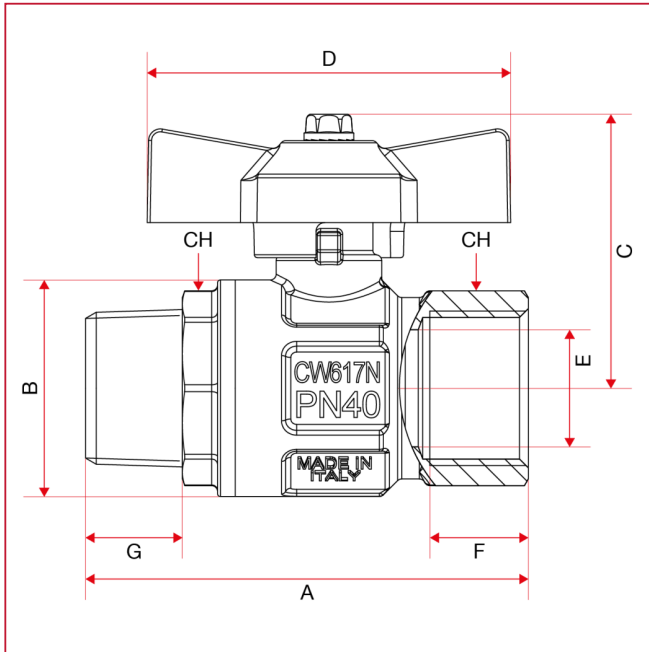

	1/4"	3/8"	1/2"	3/4"	1"
DN	8	10	15	20	25
A	56,9	58,9	68	75,5	90,5
B	23,5	24	30,5	37	45,5
C	37,3	37,3	43,8	46,8	50,8
D	47	47	54	62	62
E	8	10	15	20	25
F	11	11,4	15	16,3	19,1
G	11	11,5	15	16,5	19
CH	18	21	25	31	38
Kg/cm ² bar	5	5	5	5	5
LBS - psi	72,5	72,5	72,5	72,5	72,5



FULL FLOW GAS BALL VALVES: LONDON

MATERIALS

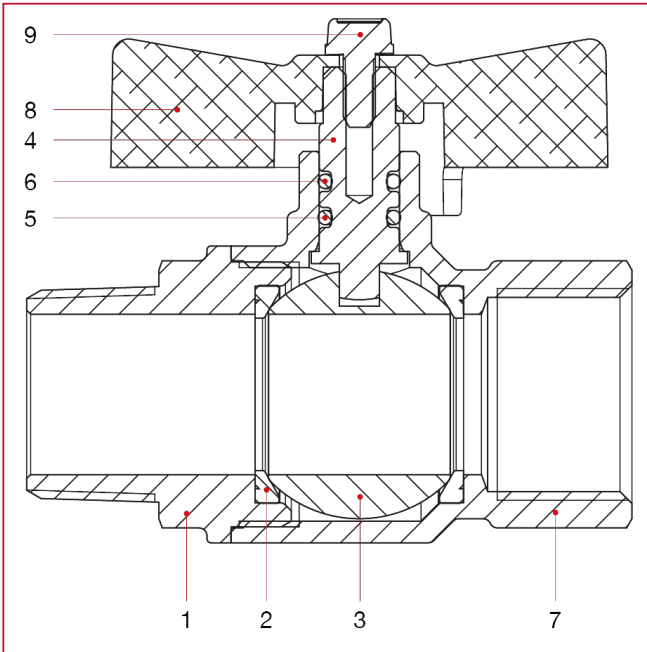

POS.	DESCRIPTION	N.	MATERIAL
1	Male end adapter	1	Nickel-plated brass CW617N
2	Seat	2	P.T.F.E.
3	Ball	1	Chrome-plated brass CW617N
4	Stem	1	Brass CW614N
5	O-ring	1	NBR
6	O-ring	1	Viton®
7	Body	1	Nickel-plated brass CW617N
8	T handle	1	Varnished aluminium
9	Screw	1	Zinc-plated steel C4C



FULL FLOW GAS BALL VALVES: LONDON

INSTALLATION

The itap S.p.A.'s valves are bi-directional, that means they manage the flow in both the directions.

The valves are composed by a ball, two seal in PTFE material, one stem, two sailing rings (O-Rings), one handle and a couple of parts made of brass (body and end adopter) that contain them and that are assembled by means of thread and a sealed material to obtain their aim.

In order to avoid that the sealed material gets broken and then the valve loses the connection between the body and the end-adapter, it's necessary to avoid to submit the two parts under the influence of a torque.

For the installation normal hydraulic practices must be used, and especially:

- ones have to be sure that the two pipes are correctly aligned;
- during the assembling process the installer has to apply its assembling tools at the end that is nearest to the pipe;
- the application of the sealing materials by the fitter (PTFE or hempen cloth) must be limited at the thread zone. An excess should interfere in the ball-gasket's closure zone, compromising the tightness.
- in the case that the fluid transported presents some impurities (dust, water too hard, etc.) ones have to remove these impurities by the means of a filter. Otherwise they could damage the seals.

DISASSEMBLY

To remove the valve from the pipe line or anyhow before to unscrew the junctions linked to it:

- wear the clothing protective normally required to work with the fluid transported within the line;
- depressurize the line and operate in this way:
 - positioning the valve in opened position and than empty the line;
 - handle the valve to put down the residue pressure contained inside the space between the ball and the body before of remove it from the line;
- during the disassembly apply the screw tool at the end of the valve nearest the pipe;

MAINTENANCE

Verify the valve periodically, according to its application's field and its works' field and its work's conditions, in order to be sure that the valve works correctly.

WARNINGS

- any deterioration or destruction of any part of the manually operated ball valve shall result in the need to replace complete valve: alterations to any part of the complete valve shall result in the valve no longer being in compliance with the performance requirements of EN 331 standard;
- ensure that the manually operated ball valve allows an adequate flow rate for its intended use;
- all installations should be performed in accordance with existing local installation regulations and codes of practice where they exist;
- it is imperative to follow the installation instructions of the manually operated ball valve manufacturer and of the appliance manufacturer, including those for the correct position of the connection point for the valve.

MANUFACTURER

ITAP S.p.A.

via Ruca 19/21 - 25065

Lumezzane (BS), Italy

Phone: +39 030 8927011

Fax: +39 030 8921990

email: info@itap.it

web: www.itap.it



FULL FLOW GAS BALL VALVES: LONDON

LOSS DIAGRAM (With water)

	1/4"	3/8"	1/2"	3/4"	1"
KV	3,45	5,00	15,65	26,26	41,44

