

NOTE:  
1. ALL DIMENSIONS ARE IN MM  
UNLESS OTHERWISE SPECIFIED.

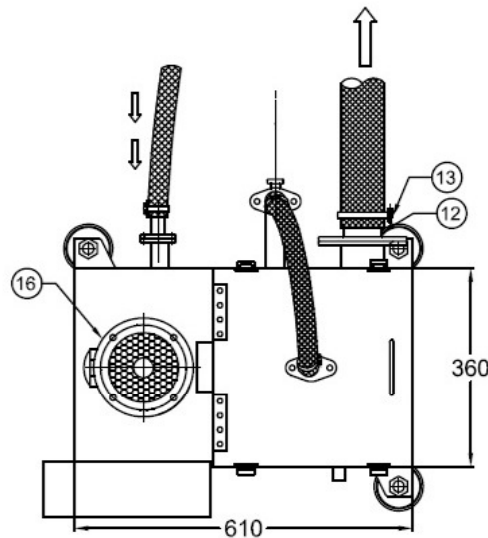
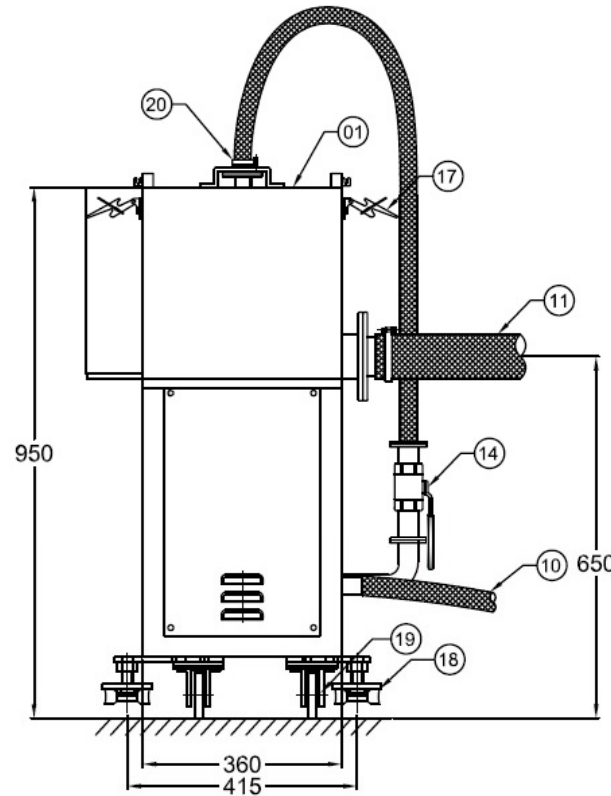
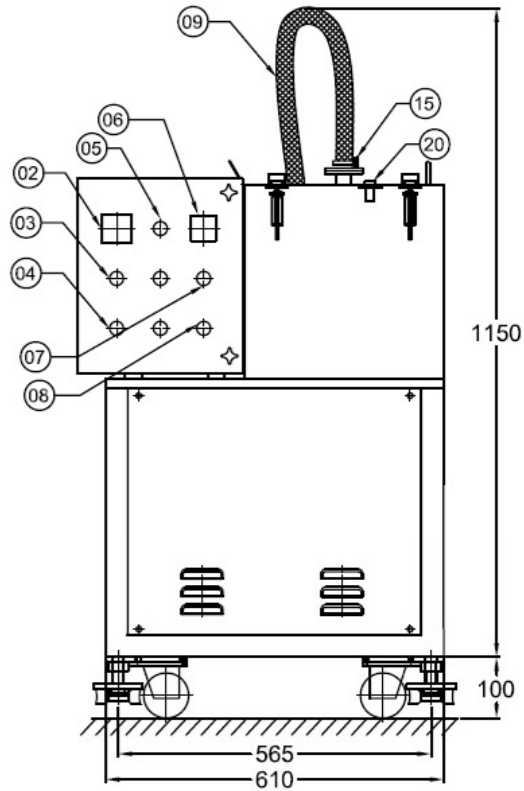

22		
21		
20	PROXIMITY MAGNETIC SWITCH	01
19	CASTOR WHEELS	04
18	ANTI-VIBRATION MOUNTS	04
17	COVER CLAMPS	04
16	DRIVE MOTOR 3 HP	01
15	HOSE CLAMPS 1"	03
14	BALL VALVE 1"	01
13	DRAIN HOSE CLAMP 2½"	01
12	DRAIN HOSE NIPPLE ½"	01
11	DRAIN HOSE 2½"	01
10	SUCTION HOSE 1"	01
9	CENTRIFUGE INLET HOSE 1"	01
8	OVERLOAD ON INDICATOR	01
7	OVERLOAD ON INDICATOR	01
6	HOUR METER	01
5	R Y B INDICATOR	03
4	OFF BUTTON	01
3	ON BUTTON	01
2	MCB	01
1	STRUCTURE	01
SR. NO.	ITEM	QTY.

Position	Alteration	Date	Name	BILL OF MATERIALS.		
Alteration Area				Scale	N.T.S.	Weight: 130 Kg.
Permissible Deviations				Surface Finish	Material Raw Material Die No.	
Drawn				Date	Name	Description
Checked				03.12.12		(ASSEMBLY)
Approved				03.12.12		
Belongs to				Substitutes		Sheet 1 OF 1
						<b>Oilybits Ltd</b>