



PERFORMANCE RANGE

- Flow rate up to **90 l/min** (5.4 m³/h)
- Head up to **100 m**

APPLICATION LIMITS

- Manometric suction lift up to **8 m**
- Liquid temperature between **-10 °C** and **+60 °C**
- Ambient temperature up to **+40 °C** (**+50 °C** for PK 60)
- Max. working pressure:
 - **6 bar** for PK 60, PK 60-MD, PK 65, PK 70, PK 80
 - **10 bar** for PK 90, PK 100, PK 200, PK 300
- Continuous service **S1**

CONSTRUCTION AND SAFETY STANDARDS

EN 60335-1
IEC 60335-1
CEI 61-150

EN 60034-1
IEC 60034-1
CEI 2-3



CERTIFICATIONS

Company with management system certified DNV
ISO 9001: QUALITY

INSTALLATION AND USE

Suitable for use with clean water that does not contain abrasive particles and with liquids that are not chemically aggressive towards the materials from which the pump is made. Because of their reliability and the fact that they are easy to use and are economical, they are ideal for domestic use and in particular for distributing water in combination with small pressure tanks and for the irrigation of gardens and orchards. The pump should be installed in an enclosed environment or sheltered from inclement weather.

PATENTS - TRADE MARKS - MODELS

- Motor bracket: patent n. IT1243605
- Shaft: patent n. 0000275945 (PK60, PK65)
- Pump body: patent n. 0000275946 (PK60, PK65)
- Registered EU Design n. 004673192
- **PKm 60**® Registered Trade Mark n. 009875394

OPTIONS AVAILABLE ON REQUEST

- Pump body with NPT ANSI B 1.20.1 threaded ports
- Special mechanical seal
- Other voltages
- IP X5 class protection for PK 70-80-90-100-200-300

GUARANTEE

2 years subject to terms and conditions

CHARACTERISTIC CURVES AND PERFORMANCE DATA

60 Hz n = 3450 min⁻¹ HS = 0 m

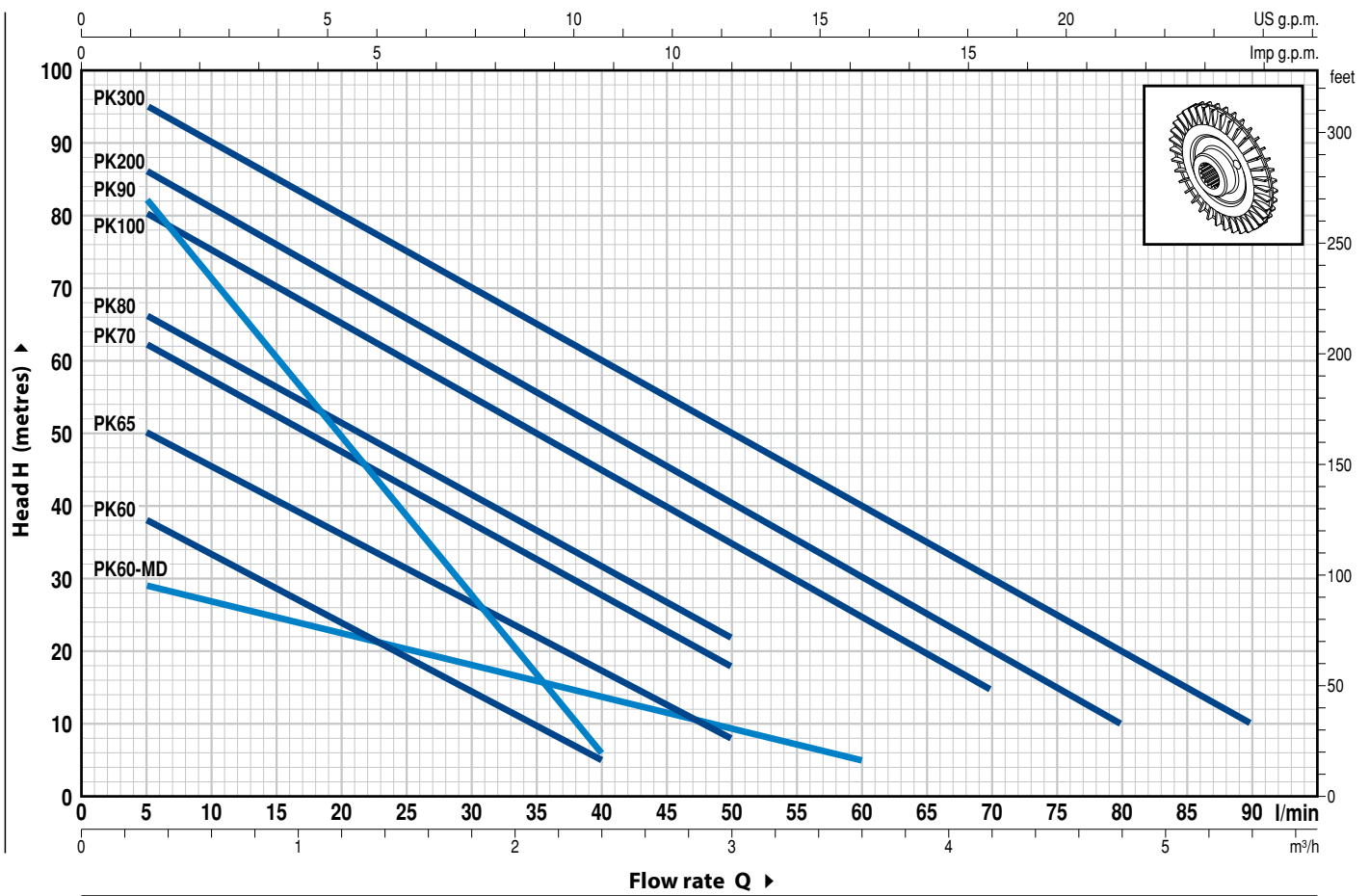

MODEL		POWER (P ₂)			Q	H metres																
Single-phase	Three-phase	kW	HP	▲		0	0.3	0.6	0.9	1.2	1.5	1.8	2.1	2.4	3.0	3.6	4.2	4.8	5.4			
					0	5	10	15	20	25	30	35	40	50	60	70	80	90				
PKm 60°	PK 60°	0.37	0.50	IE2	40	38	33.5	29	24	19.5	15	10	5									
PKm 60°-MD	PK 60°-MD	0.37	0.50		30	29	26.5	24.5	22.5	20.5	18	16	13.5	9.5	5							
PKm 65	PK 65	0.50	0.70	IE3	55	50	45.5	40.5	36	31	27	22	17	8								
PKm 70	PK 70	0.60	0.85		65	62	57	52	47	42	37	32	27	18								
PKm 80	PK 80	0.75	1		70	66	61	56	51	46	41	36.5	31	22								
PKm 90	PK 90	0.75	1		90	82	71	60	49	38	27	17	5									
PKm 100	PK 100	1.1	1.5		85	80	75	70	65	60	55	50	45	35	25	15						
PKm 200	PK 200	1.5	2		90	86	81	76	71	65.5	60	55	50	40	30	20	10					
-	PK 300	2.2	3		100	95	90	85	80	75	70	65	60	50	40	30	20	10				

Q = Flow rate H = Total manometric head HS = Suction height

Tolerance of characteristic curves in compliance with EN ISO 9906 Grade 3B.

▲ Three phase motor efficiency class (IEC 60034-30-1)

POS. COMPONENT CONSTRUCTION CHARACTERISTICS

1 PUMP BODY	Cast iron, with threaded ports in compliance with ISO 228/1 (PK 60, PK 60-MD with an Epoxy Electro Coating treatment)					
2 MOTOR BRACKET	Aluminium with brass insert (patented), reduces the risk of impeller seizure					
3 IMPELLER	Brass with peripheral radial vanes					
4 MOTOR SHAFT	Stainless steel EN 10088-3 - 1.4104					
5 MECHANICAL SEAL	<i>Pump</i>	<i>Seal</i>	<i>Shaft</i>		<i>Materials</i>	
	<i>Model</i>	<i>Model</i>	<i>Diameter</i>	<i>Stationary ring</i>	<i>Rotational ring</i>	<i>Elastomer</i>
	PK 60-65-70-80 PK60-MD	AR-12	Ø 12 mm	Ceramic	Graphite	NBR
	PK 90 PK 100-200-300	ST1-12 FN-14	Ø 12 mm Ø 14 mm	Silicon carbide Graphite	Graphite Ceramic	NBR NBR
6 BEARINGS	<i>Pump</i>	<i>Model</i>				
	PK 60-65 PK60-MD	6201 ZZ / 6201 ZZ				
	PK 70-80-90	6203 ZZ / 6203 ZZ				
	PK 100-200-300	6204 ZZ / 6204 ZZ				
7 CAPACITOR	<i>Pump</i>	<i>Capacitance</i>				
	<i>Single-phase</i>	<i>(220 V)</i>		<i>(110 V or 127 V)</i>		
	PKm 60 PKm60-MD	10 µF - 450 VL	25 µF - 250 VL			
	PKm 65	14 µF - 450 VL	25 µF - 250 VL			
	PKm 70	16 µF - 450 VL	60 µF - 300 VL			
	PKm 80	20 µF - 450 VL	60 µF - 300 VL			
	PKm 90	20 µF - 450 VL	60 µF - 300 VL			
	PKm 100 PKm 200	31.5 45 µF - 450 VL	60 80 µF - 250 VL			
8 ELECTRIC MOTOR	PKm: single-phase 220 V - 60 Hz with thermal overload protector incorporated into the winding.					
	PK: three-phase 220/380 V - 60 Hz or 220/440 V - 60 Hz.					
	<p>⇒ The three-phase pumps are fitted with high performance motors up to P₂=0.50 kW in class IE2 and from P₂=0.60 kW in class IE3 (IEC 60034-30-1)</p> <ul style="list-style-type: none"> - Insulation: class F - Protection: IP X4 					

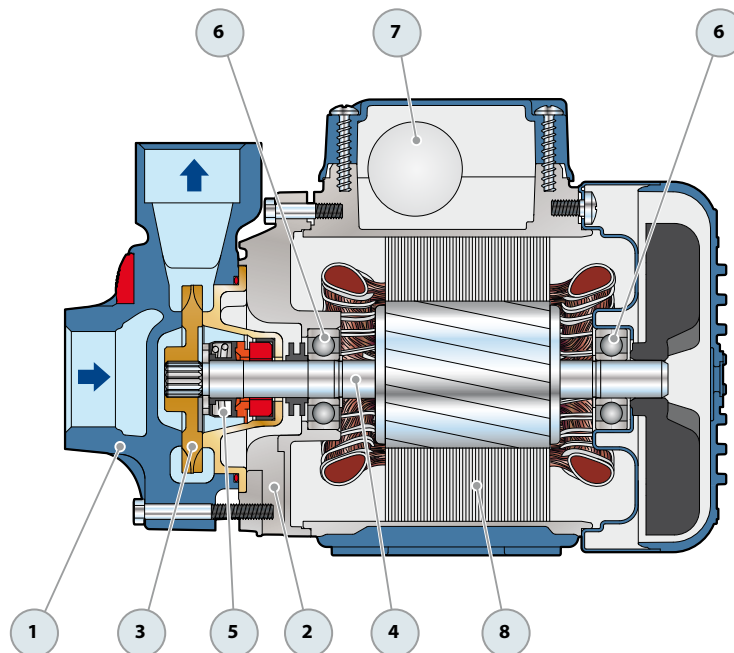

DIMENSIONS AND WEIGHT

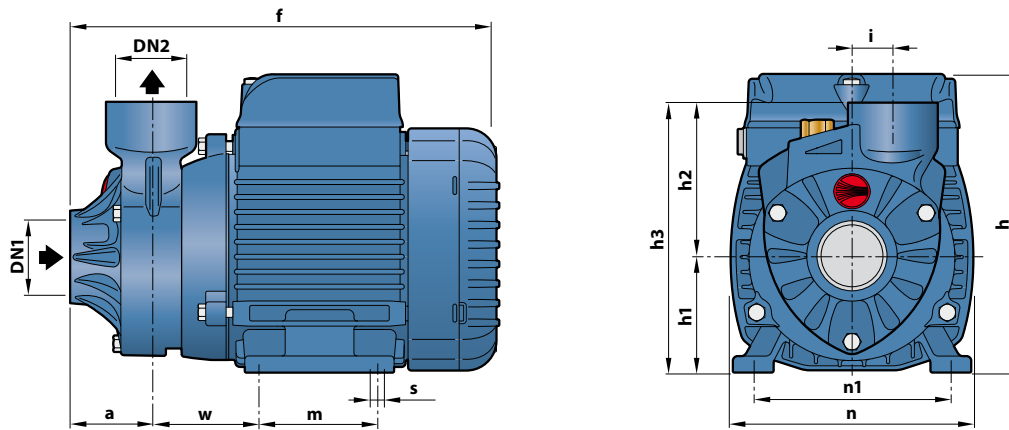

MODEL		PORTS		DIMENSIONS mm												kg			
Single-phase	Three-phase	DN1	DN2	a	f	h	h1	h2	h3	i	m	n	n1	w	s	1~	3~		
PKm 60°	PK 60°	1"	1"	39	207	145	56	75	131	20	55	118	93-100	53	7	5.2	5.2		
PKm 60°-MD	PK 60°-MD				236	152	63		138		80	120	100			5.6	5.6		
PKm 65	PK 65				285	180*	71		85		156	90	140			112	62	10.0	9.9
PKm 70	PK 70				278	84	155		19		10.0	10.0							
PKm 80	PK 80	3/4"	3/4"	46	278	80	94	174	20	100	164	125	85	9	14.4	14.3			
PKm 90	PK 90	1"	1"	55	350	212	80	94	174	20	100	164	125	85	9	15.5	15.5		
PKm 100	PK 100															370	10.0	10.0	
PKm 200	PK 200															370	10.0	10.0	
-	PK 300	-	-	-	370	-	-	-	-	-	-	-	-	-	-	-	18.1		

(*) h=199 mm for single phase versions at 110V or 127 V

ABSORPTION

MODEL	VOLTAGE		
Single-phase	220 V	110 V	127 V
PKm 60°	2.6 A	5.5 A	5.3 A
PKm 60°-MD	3.2 A	6.5 A	6.0 A
PKm 65	5.8 A	11.6 A	10.0 A
PKm 70	5.2 A	10.8 A	10.0 A
PKm 80	6.5 A	13.0 A	12.0 A
PKm 90	6.0 A	12.0 A	11.0 A
PKm 100	9.0 A	18.0 A	16.5 A
PKm 200	12.0 A	24.0 A	22.3 A

MODEL	VOLTAGE			
Three-phase	220 V	380 V	220 V	440 V
PK 60°	2.0 A	1.15 A	2.1 A	1.2 A
PK 60°-MD	2.1 A	1.2 A	2.2 A	1.3 A
PK 65	3.2 A	1.85 A	3.5 A	2.0 A
PK 70	3.8 A	2.2 A	3.8 A	2.2 A
PK 80	3.8 A	2.2 A	4.3 A	2.4 A
PK 90	4.2 A	2.4 A	4.2 A	2.4 A
PK 100	6.2 A	3.6 A	6.2 A	3.15 A
PK 200	9.5 A	5.6 A	7.0 A	4.2 A
PK 300	10.0 A	5.8 A	8.2 A	4.8 A

PALLETIZATION

MODEL		GROUPAGE	CONTAINER
Single-phase	Three-phase	n. pumps	n. pumps
PKm 60°	PK 60°	240	330
PKm 60°-MD	PK 60°-MD	189	243
PKm 65	PK 65	189	243
PKm 70	PK 70	102	170
PKm 80	PK 80	102	170
PKm 90	PK 90	102	170
PKm 100	PK 100	72	96
PKm 200	PK 200	72	96
-	PK 300	72	96