

# AC PUMPS VISCOMAT GEAR



**EN.** Gear Pumps. The “Viscomat” is a family of internal profile gear pumps designed as the modern, effective solutions for various requirements of pumping oils and lubricants.

**ES.** Bombas de engranajes. “Viscomat” es una familia de bombas de engranajes con perfil interno que ha sido concebida como una válida y moderna solución para las diferentes exigencias de bombeo de los aceites lubricantes.

**PT.** Bombas a engrenagens. “Viscomat” é uma família de bombas de engrenagens de perfil interno concebidas como soluções válidas e modernas para as várias exigências para bombear óleos lubrificantes.

## PERFORMANCE

- Viscosity up to 2000 cSt
- Flow rates 9 - 14 l/min.
- Pressures 12 - 25 bar
- Continuous AC operation.
- Noise level below 70 dB

- Viscosidad hasta 2000 cSt
- Caudales 9 - 14 l/min
- Presiones hasta 12 - 25 bar
- Funcionamiento continuo CA
- Nivel sonoro inferior a 70 dB

- Viscosidade até 2000 cSt
- Caudal de 9 a 14 l/min.
- Pressões até 12 a 25 bar
- Funcionamento contínuo AC
- Ruído inferior a 70 dB

## DIMENSIONS

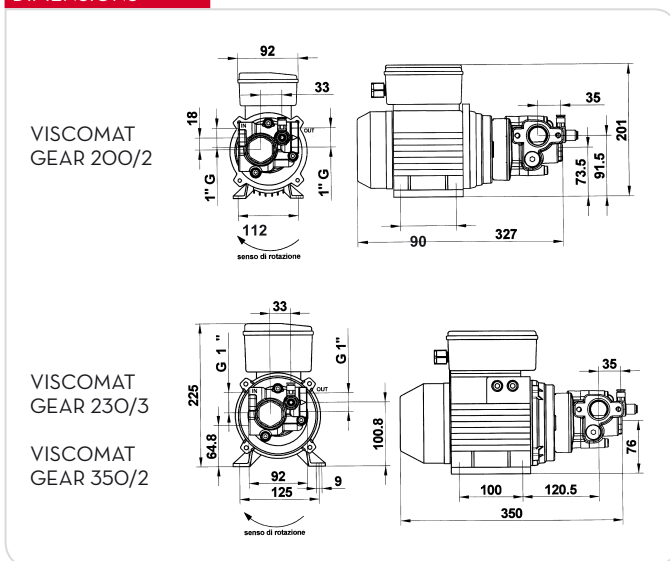

## PRODUCTS' RANGE WEIGHT AND PACKAGING

Code	Weight		Packaging		
	kg	lbs	mm	inch	pcs/box
F0030403D	9	19,8	350x200x280	13,8x7,9x11	1
F0030420D	9	19,8	350x200x280	13,8x7,9x11	1
F0030430D	12,5	27,6	350x200x280	13,8x7,9x11	1
F0030401D	12,5	27,6	350x200x280	13,8x7,9x11	1
F0030411D	12,5	27,6	350x200x280	13,8x7,9x11	1

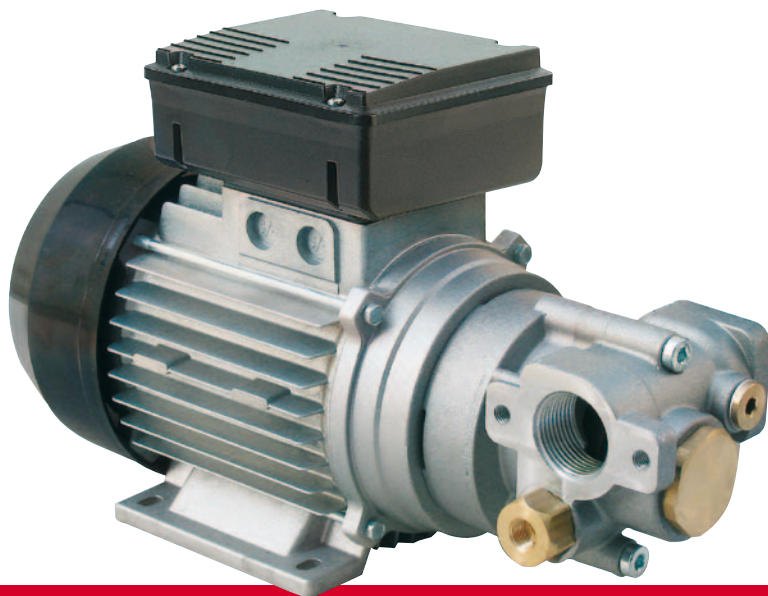

**Flow-rate**

up to  
**14** l/min  
(up to 3,7 gpm)

**Viscosity**

up to  
**2000**  
cSt

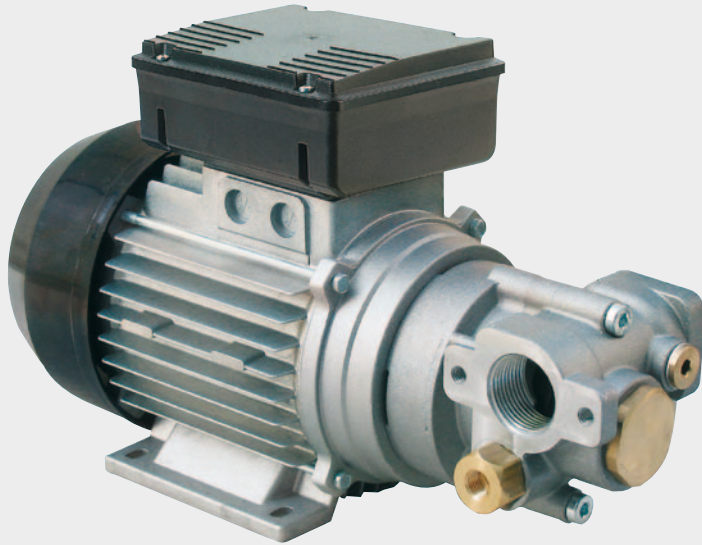

VISCOMAT GEAR

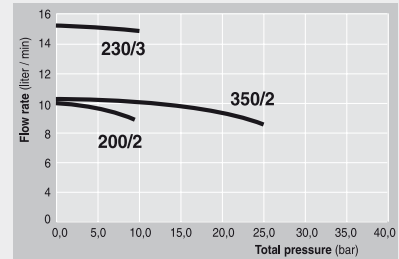

Max suction height  
- 2 m (7 Ft)  
w/o no back valve  
- 4 m (14 Ft)  
w no back valve  
- Tubo Ø 1"

**FEATURES**

**Gear rotor**



**Adjustable bypass valve**



**ON REQUEST**

**Flanged connection (optional)**



**PRODUCTS' RANGE TECHNICAL DATA**

Code	Description	Fluids type	Flow-rate		Pressure		Voltage			rpm	Inlet Outlet	Bypass valve
			l/min	gpm	bar	psi	Singlephase motor V./Hz	Power Watt	Amp. max.			
F0030403D	Viscomat 200/2 M.	☉	9	2,4	12	170	230/50/60	800/950	3,8/4,6	1450/1700	1" BSP	YES
F0030420D	Viscomat 200/2 120V/60Hz	☉	9	2,4	12	170	120/60	1500	15	1730	3/4" NPTF	YES
F0030430D	Viscomat 230/3 M.	☉	14	3,7	12	170	230/50	1250	6	1400	1" BSP	YES
F0030401D	Viscomat 350/2 M.	☉	9	2,4	25	355	230/50	1200	6	1250	1" BSP	YES
F0030411D	Viscomat 350/2 120V/60Hz	☉	9	2,4	25	355	120/60	1500	13	1750	3/4" NPTF	YES

Upon request it is available with different voltage and frequency - (\*) Without Adjustable Bypass valve