

2-4CP

Multi-stage centrifugal pumps

 Clean water

 Domestic use

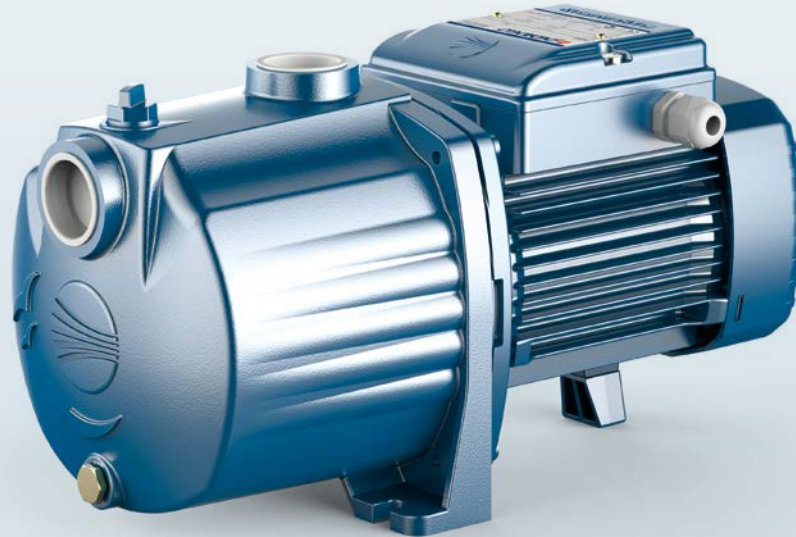

PERFORMANCE RANGE

- Flow rate up to **130 l/min** (7.8 m³/h)
- Head up to **52 m**

APPLICATION LIMITS

- Manometric suction lift up to **7 m**
- Liquid temperature between **-10 °C** and **+40 °C**
- Ambient temperature up to **+40 °C**
- Max. working pressure **6 bar**
- Continuous service **S1**

CONSTRUCTION AND SAFETY STANDARDS

EN 60335-1
IEC 60335-1
CEI 61-150

EN 60034-1
IEC 60034-1
CEI 2-3



INSTALLATION AND USE

Suitable for use with clean water and with liquids that are not chemically aggressive towards the materials from which the pump is made. As a result of their quietness, these pumps are widely used in domestic applications such as the distribution of water in combination with small and medium sized pressure tanks, and for the irrigation of gardens and orchards, etc.

The pump should be installed in an enclosed environment or sheltered from inclement weather.

PATENTS - TRADE MARKS - MODELS

- Registered EU Design n. 002073635-0001

OPTIONS AVAILABLE ON REQUEST

- Other voltages or 60 Hz frequency

CERTIFICATIONS

Company with management system certified DNV
ISO 9001: QUALITY



CHARACTERISTIC CURVES AND PERFORMANCE DATA

50 Hz n = 2900 min⁻¹ HS = 0 m

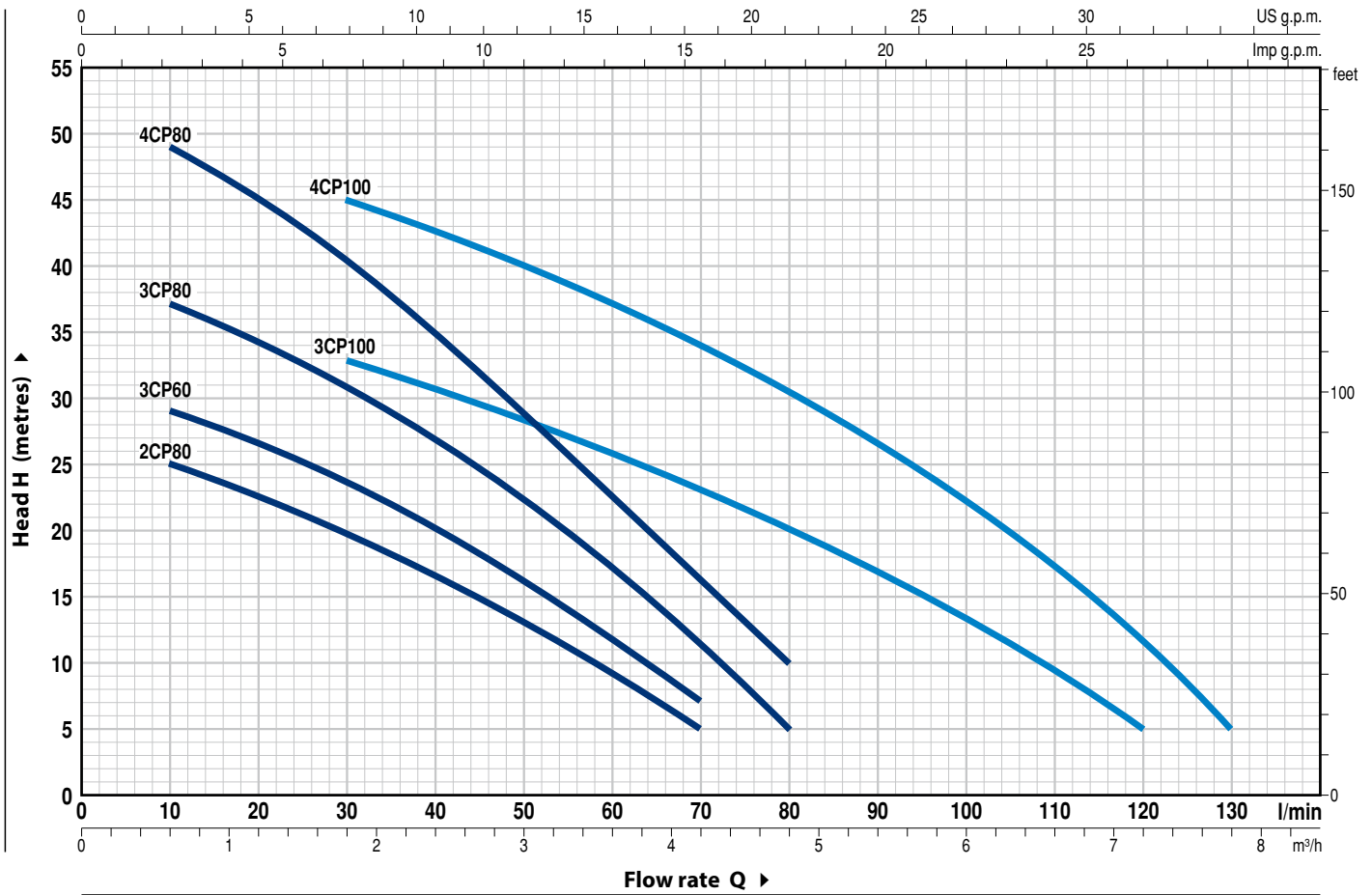

MODEL		POWER (P ₂)			Q	H metres																			
Single-phase	Three-phase	kW	HP	▲		m ³ /h	0	0.3	0.6	0.9	1.2	1.5	1.8	2.4	3.0	3.6	4.2	4.8	5.4	6.0	6.6	7.2	7.8		
					l/min	0	5	10	15	20	25	30	40	50	60	70	80	90	100	110	120	130			
2CPm 80	2CP 80	0.37	0.50	IE2	H metres	27	26	25	24	22.5	21	20	16.5	13	9	5									
3CPm 60	3CP 60	0.37	0.50			30	30	29	28	26.5	25	23.5	20	16	11.5	7									
3CPm 80	3CP 80	0.45	0.60			40	38	37	36	34.5	33	31	27	22.5	17	11	5								
4CPm 80	4CP 80	0.55	0.75			52	50	49	47	44.5	42	40	34	28.5	22.5	16	10								
3CPm 100	3CP 100	0.55	0.75	IE2		38	37	36	35	34.5	33.5	33	31	28	26	23	20	17	13.5	10	5				
4CPm 100	4CP 100	0.75	1	IE3		50	50	49	48	47	46	45	42	39.5	37	34	30.5	26.5	22	17	11	5			

Q = Flow rate H = Total manometric head HS = Suction height

Tolerance of characteristic curves in compliance with EN ISO 9906 Grade 3B.

▲ Performance class of the three-phase motor (IEC 60034-30-1)

2-4CP

POS. COMPONENT CONSTRUCTION CHARACTERISTICS

1	PUMP BODY	Cast iron with an Epoxy Electro Coating treatment, with threaded ports in compliance with ISO 228/1				
2	BODY BACKPLATE	Stainless steel AISI 304				
3	IMPELLERS	Noryl FE1520PW				
4	DIFFUSERS	Noryl complete with anti-wear ring				
5	MOTOR SHAFT	Stainless steel EN 10088-3 - 1.4104				
6	MECHANICAL SEAL	<i>Seal</i>	<i>Shaft</i>	<i>Materials</i>		
		<i>Model</i>	<i>Diameter</i>	<i>Stationary ring</i>	<i>Rotational ring</i>	<i>Elastomer</i>
		AR-13	Ø 13 mm	Ceramic	Graphite	NBR
7	BEARINGS	<i>Pump</i>	<i>Model</i>			
		2CP 80				
		3CP 60				
		3CP 80	6202 ZZ - C3 / 6201 ZZ			
		4CP 80				
3CP 100						
4CP 100	6203 ZZ / 6203 ZZ					
8	CAPACITOR	<i>Pump</i>	<i>Capacitance</i>			
		<i>Single-phase</i>	(220-230 V or 240 V)	(110 V)		
		2CPm 80	10 µF - 450 VL	25 µF - 250 VL		
		3CPm 60	12.5 µF - 450 VL	25 µF - 250 VL		
		3CPm 80	14 µF - 450 VL	25 µF - 250 VL		
		4CPm 80	20 µF - 450 VL	60 µF - 300 VL		
		3CPm 100				
4CPm 100						
9	ELECTRIC MOTOR	<p>2-4CPm: single-phase 220-230 V - 50 Hz with thermal overload protector incorporated into the winding.</p> <p>2-4CP: three-phase 230/400 V - 50 Hz.</p> <p>→ The three-phase pumps are fitted with high performance motors up to P2=0.55 kW in class IE2 and from P2=0.75 kW in class IE3 (IEC 60034-30-1)</p> <p>- Insulation: class F</p> <p>- Protection: IP X4</p>				

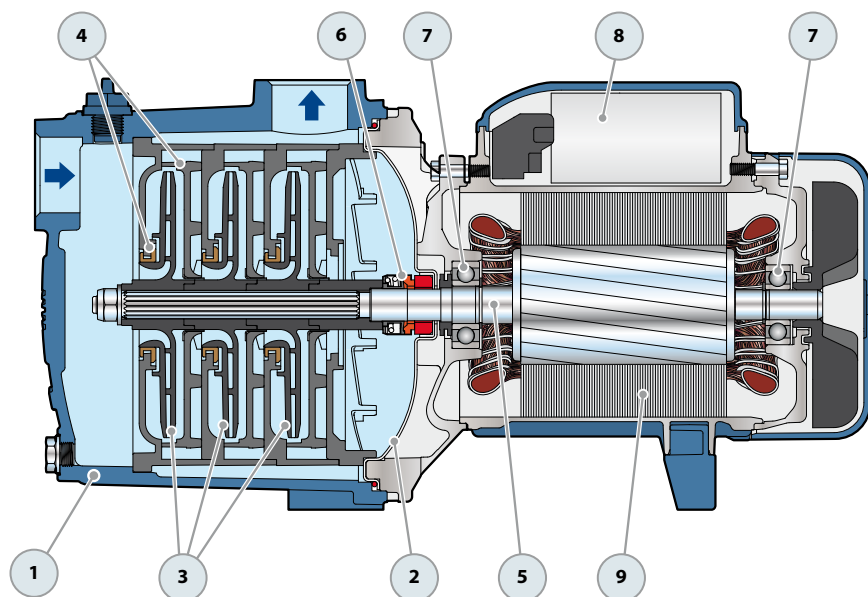

DIMENSIONS AND WEIGHT

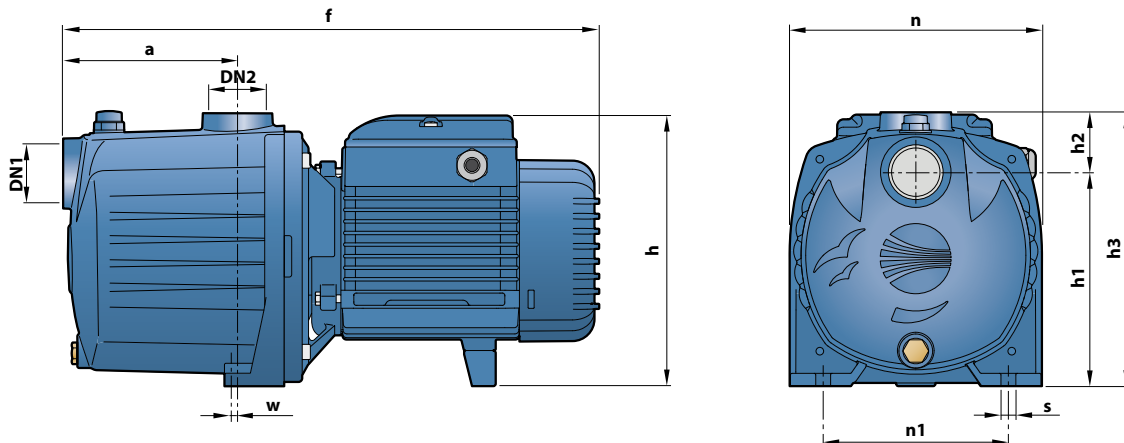

MODEL		PORTS		DIMENSIONS mm										kg	
Single-phase	Three-phase	DN1	DN2	a	f	h	h1	h2	h3	n	n1	w	s	1~	3~
2CPm 80	2CP 80	1"	1"	85	313	172	134	38	172	158	116	1.5	9	8.5	8.5
3CPm 60	3CP 60													8.6	8.6
3CPm 80	3CP 80			10.0	10.0										
4CPm 80	4CP 80			110	338	10.8	10.2								
3CPm 100	3CP 100			10.7	10.0										
4CPm 100	4CP 100			356	191 *	13.2	13.2								

(*) h=210 mm for single phase versions at 110 V

ABSORPTION

MODEL	VOLTAGE		
	220-230 V	240 V	110 V
2CPm 80	2.4 A	2.3 A	4.8 A
3CPm 60	2.4 A	2.3 A	4.8 A
3CPm 80	3.4 A	3.3 A	6.8 A
4CPm 80	4.1 A	4.0 A	8.2 A
3CPm 100	4.1 A	4.0 A	8.2 A
4CPm 100	6.0 A	5.8 A	12.0 A

MODEL	VOLTAGE					
	230 V	400 V	690 V	240 V	415 V	720 V
2CP 80	1.7 A	1.0 A	0.6 A	1.6 A	0.9 A	0.5 A
3CP 60	1.7 A	1.0 A	0.6 A	1.6 A	0.9 A	0.5 A
3CP 80	2.5 A	1.5 A	0.9 A	2.4 A	1.4 A	0.8 A
4CP 80	3.4 A	2.0 A	1.2 A	3.3 A	1.9 A	1.1 A
3CP 100	3.4 A	2.0 A	1.2 A	3.3 A	1.9 A	1.1 A
4CP 100	4.0 A	2.3 A	1.3 A	3.8 A	2.2 A	1.3 A

PALLETIZATION

MODEL		GROUPAGE	CONTAINER
Single-phase	Three-phase	n. pumps	n. pumps
2CPm 80	2CP 80	98	140
3CPm 60	3CP 60	98	140
3CPm 80	3CP 80	84	120
4CPm 80	4CP 80	84	120
3CPm 100	3CP 100	84	120
4CPm 100	4CP 100	84	108