

## Submersible drainage pumps

-  Clear water
-  Domestic use
-  Civil use



### PERFORMANCE RANGE

- Flow rate up to **300 l/min** (18 m<sup>3</sup>/h)
- Head up to **26 m**

### APPLICATION LIMITS

- **10 m** maximum immersion depth (with a sufficiently long power cable)
- Maximum liquid temperature **+40 °C**
- Passage of suspended solids up to **Ø 10 mm**
- Suction down to **17 mm** above ground level
- Minimum immersion depth for continuous service: **220 mm**

### CONSTRUCTION AND SAFETY STANDARDS

- **10 m** long power cable
- Float switch for single-phase versions

EN 60335-1  
IEC 60335-1  
CEI 61-150

EN 60034-1  
IEC 60034-1  
CEI 2-3



### CERTIFICATIONS

Company with management system certified DNV  
ISO 9001: QUALITY  
ISO 14001: ENVIRONMENT

### INSTALLATION AND USE

DC submersible pumps, made from heavy gauge cast iron offering exceptional sturdiness, abrasion resistance and durability, are suitable for draining **clear or slightly dirty water**. They distinguish themselves for their sturdiness and reliability under automatic operating conditions in fixed installations.

### PATENTS - TRADE MARKS - MODELS

- Patent Pending n. BO2015A000116
- Registered EU Design n. 002501486-0001

### OPTIONS AVAILABLE ON REQUEST

- Single-phase pumps without float switch
- Other voltages

### GUARANTEE

2 years subject to terms and conditions

## CHARACTERISTIC CURVES AND PERFORMANCE DATA

60 Hz n = 3450 rpm

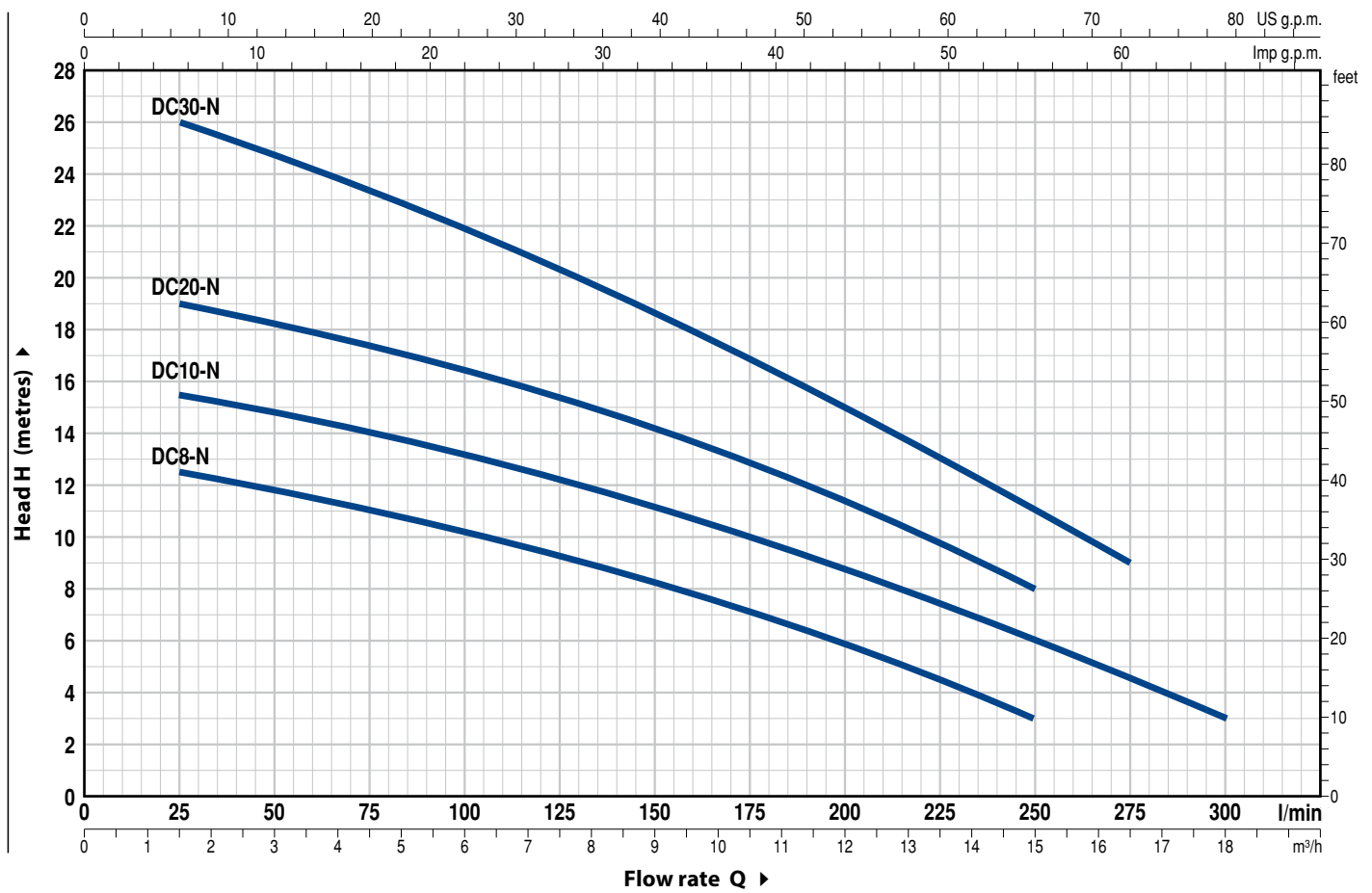

MODEL		POWER (P <sub>2</sub> )		Q	Flow rate																	
Single-phase	Three-phase	kW	HP		m <sup>3</sup> /h	0	1.5	3.0	4.5	6.0	7.5	9.0	10.5	12.0	13.2	15.0	16.5	18.0				
				l/min	0	25	50	75	100	125	150	175	200	225	250	275	300					
DCm 8 -N	DC 8 -N	0.55	0.75	H metres	13	12.5	11.8	11	10.2	9.2	8.2	7	5.8	4.7	3							
DCm 10-N	DC 10-N	0.75	1		16	15.5	14.8	14	13.2	12.2	11.2	10	8.8	7.8	6	4.5	3					
DCm 20-N	DC 20-N	0.75	1		20	19	18.5	17.5	16.5	15.5	14.3	13	11.5	10	8							
DCm 30-N	DC 30-N	1.1	1.5		26	26	24.8	23.5	22	20.4	18.7	16.9	15	13.5	11	9						

Q = Flow rate H = Total manometric head

Tolerance of characteristic curves in compliance with EN ISO 9906 Grade 3B.

## POS. COMPONENT CONSTRUCTION CHARACTERISTICS

1	<b>PUMP BODY</b>	Cast iron with an Epoxy Electro Coating treatment, with threaded port in compliance with ISO 228/1
2	<b>SUCTION FILTER</b>	Stainless steel AISI 304
3	<b>SUCTION PLATE</b>	Stainless steel AISI 304
4	<b>IMPELLER</b>	Technopolymer open type
5	<b>MOTOR CASING</b>	Cast iron with an Epoxy Electro Coating treatment
6	<b>MOTOR CASING PLATE</b>	Stainless steel AISI 304
7	<b>MOTOR SHAFT</b>	Stainless steel EN 10088-3 - 1.4104

### 8 SHAFT WITH DOUBLE MECHANICAL SEAL SEPARATED BY AN OIL CHAMBER

Pump Model	Seal Model	Shaft Diameter	Position	Materials		
				Stationary ring	Rotational ring	Elastomer
DC8 -N	MG1-14D SIC	Ø 14 mm	Motor side	Silicon carbide	Graphite	NBR
DC10-N			Pump side	Silicon carbide	Silicon carbide	NBR
DC20-N						
<b>(Double seal on shaft with a ring seal Ø 16 x Ø 24 x H 5 mm)</b>						
DC30-N	ST1-14 SIC	Ø 14 mm		Ceramic	Silicon carbide	NBR

### 9 BEARINGS 6203 ZZ / 6203 ZZ

### 10 CAPACITOR

Pump Model	Capacitance	
Single-phase	(220 V)	(110 V or 127 V)
DCm8 -N	20 µF - 450 VL	30 µF - 250 VL
DCm10-N		
DCm20-N		
DCm30-N	25 µF - 450 VL	-

### 11 ELECTRIC MOTOR

**DCm:** single-phase 220 V - 60 Hz  
with thermal overload protector incorporated into the winding

**DC:** three-phase 380 V - 60 Hz

- Insulation: class F
- Protection: IP X8

### 12 POWER CABLE

"H07 RN-F" type  
(with Schuko plug for single-phase versions only)

**Standard length 10 metres**

### 13 FLOAT SWITCH

(only for single-phase versions)

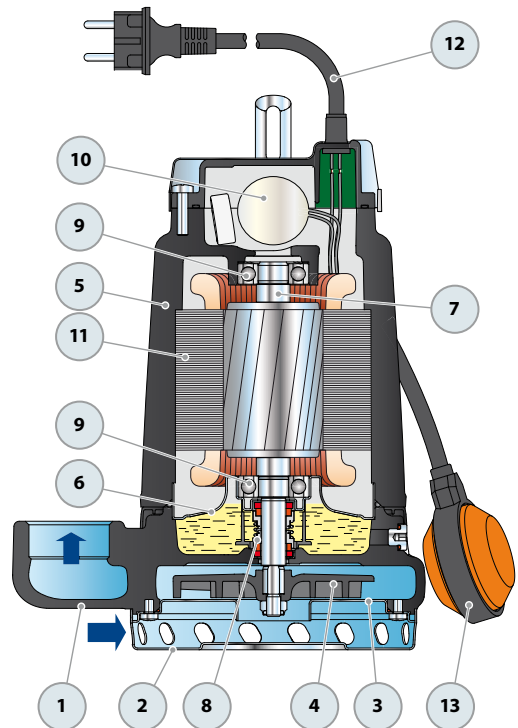

## DIMENSIONS AND WEIGHT

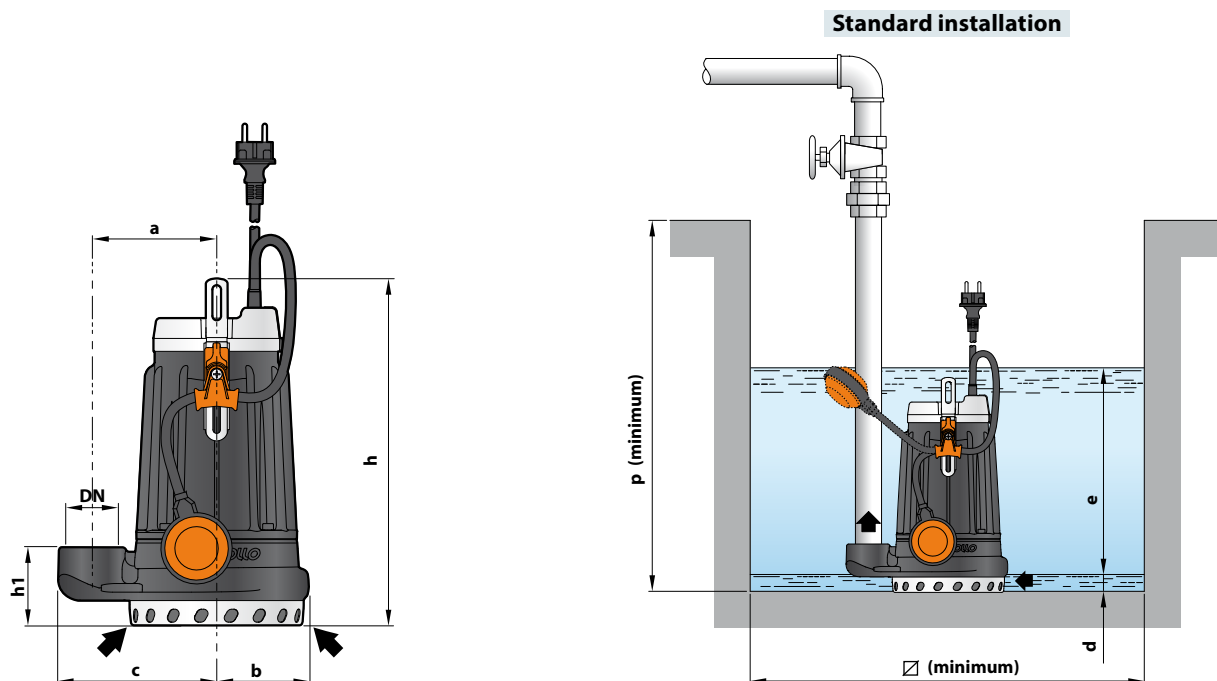

MODEL		PORT DN	DIMENSIONS mm									kg	
Single-phase	Three-phase		a	b	c	h	h1	d	e	p	∅	1~	3~
DCm 8 -N	DC 8 -N	1½"	115	85	147	322	72	17	variable	500	500	16.1	15.8
DCm 10-N	DC 10-N											17.2	16.1
DCm 20-N	DC 20-N			17.2		16.1							
DCm 30-N	DC 30-N			18.8		17.8							

## ABSORPTION

MODEL	VOLTAGE		
	220 V	110 V	127 V
DCm 8 -N	3.8 A	7.6 A	6.8 A
DCm 10-N	5.0 A	10.0 A	9.5 A
DCm 20-N	6.5 A	13.0 A	12.0 A
DCm 30-N	7.7 A	-	-

MODEL	VOLTAGE		
	220 V	380 V	440 V
DC 8 -N	3.2 A	1.8 A	1.6 A
DC 10-N	3.9 A	2.3 A	2.0 A
DC 20-N	4.9 A	2.8 A	2.5 A
DC 30-N	5.7 A	3.3 A	2.9 A

## PALLETIZATION

MODEL		GROUPAGE n. pumps	CONTAINER n. pumps
Single-phase	Three-phase		
DCm 8 -N	DC 8 -N	60	80
DCm 10-N	DC 10-N	60	80
DCm 20-N	DC 20-N	60	80
DCm 30-N	DC 30-N	60	80