

## Submersible pumps

 Filthy water

 Domestic use

 Civil use



### PERFORMANCE RANGE

- Flow rate up to **750 l/min** (45 m<sup>3</sup>/h)
- Head up to **15 m**

### APPLICATION LIMITS

- **10 m** maximum immersion depth (with a sufficiently long power cable)
- Maximum liquid temperature **+40 °C**
- Passage of suspended solids up to **Ø 50 mm**
- Minimum immersion depth for continuous service: **300 mm**

### CONSTRUCTION AND SAFETY STANDARDS

- **10 m** long power cable
- Float switch for single-phase versions

EN 60335-1  
IEC 60335-1  
CEI 61-150

EN 60034-1  
IEC 60034-1  
CEI 2-3



### CERTIFICATIONS

Company with management system certified DNV  
ISO 9001: QUALITY  
ISO 14001: ENVIRONMENT

### INSTALLATION AND USE

**MC** series pumps, made from heavy gauge cast iron offering exceptional sturdiness, abrasion resistance and durability, come equipped with a **DOUBLE-CHANNEL** impeller and are capable of pumping liquids containing short fibred suspended solids up to Ø 50 mm.

Recommended for conveying **drained water and sewage, waste water, water mixed with mud, groundwater and surface water** for applications in blocks of flats, industries, multi-storey and underground car parks, wash areas, etc.

### PATENTS - TRADE MARKS - MODELS

- Patent Pending n. BO2015A000116
- Registered EU Design n. 002501486-0003

### OPTIONS AVAILABLE ON REQUEST

- Single-phase pumps without float switch
- Other voltages

### GUARANTEE

2 years subject to terms and conditions

### CHARACTERISTIC CURVES AND PERFORMANCE DATA

60 Hz n= 3450 rpm

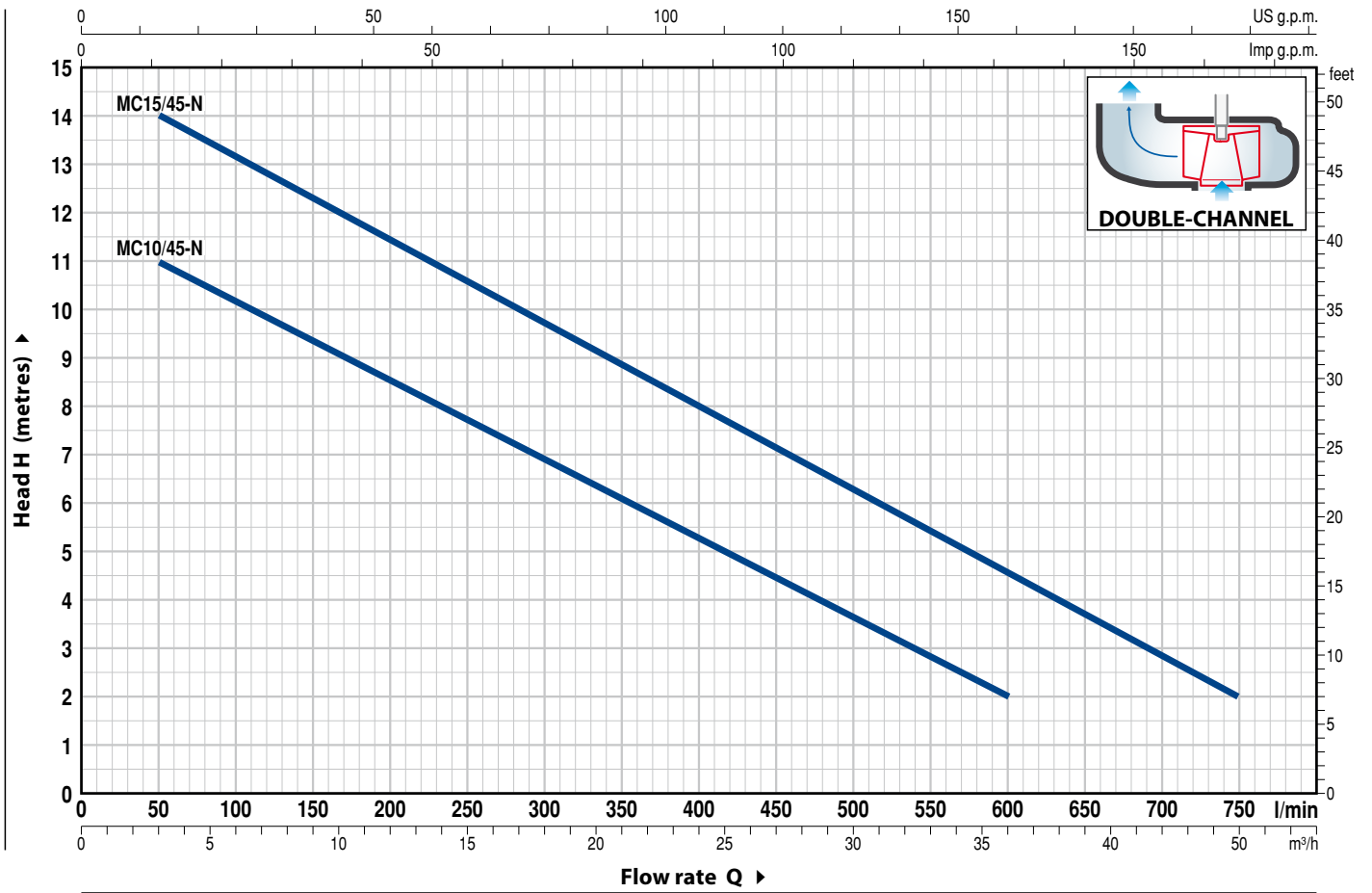

MODEL		POWER (P <sub>2</sub> )		Q	Flow rate													
Single-phase	Three-phase	kW	HP		m <sup>3</sup> /h	0	3	6	12	18	24	30	36	42	45			
				l/min	0	50	100	200	300	400	500	600	700	750				
MCm 10/45-N	MC 10/45-N	0.75	1	H metres	12	11	10	8.5	7	5	3.5	2						
MCm 15/45-N	MC 15/45-N	1.1	1.5		15	14	13	11.5	9.7	8	6.3	4.5	3	2				

Q = Flow rate H = Total manometric head

Tolerance of characteristic curves in compliance with EN ISO 9906 Grade 3B.

## POS. COMPONENT CONSTRUCTION CHARACTERISTICS

1	<b>PUMP BODY</b>	Cast iron with an Epoxy Electro Coating treatment, with threaded port in compliance with ISO 228/1
2	<b>BASE</b>	Stainless steel AISI 304
3	<b>IMPELLER</b>	Precision cast stainless steel AISI 304 DOUBLE-CHANNEL type
4	<b>MOTOR CASING</b>	Cast iron with an Epoxy Electro Coating treatment
5	<b>MOTOR CASING PLATE</b>	Stainless steel AISI 304
6	<b>MOTOR SHAFT</b>	Stainless steel EN 10088-3 - 1.4104

### 7 SHAFT WITH DOUBLE MECHANICAL SEAL SEPARATED BY AN OIL CHAMBER

Seal Model	Shaft Diameter	Position	Materials		
			Stationary ring	Rotational ring	Elastomer
MG1-14D SIC	Ø 14 mm	Motor side	Silicon carbide	Graphite	NBR
		Pump side	Silicon carbide	Silicon carbide	NBR

### 8 BEARINGS 6203 ZZ / 6203 ZZ

### 9 CAPACITOR

Pump	Capacitance	
Single-phase	(220 V)	(110 V or 127 V)
MCm 10/45-N	20 µF - 450 VL	30 µF - 250 VL
MCm 15/45-N	25 µF - 450 VL	-

### 10 ELECTRIC MOTOR

**MCm:** single-phase 220 V - 60 Hz  
with thermal overload protector incorporated into the winding

**MC:** three-phase 380 V - 60 Hz

- Insulation: class F
- Protection: IP X8

### 11 POWER CABLE

"H07 RN-F" type  
(with Schuko plug for single-phase versions only)

**Standard length 10 metres**

### 12 FLOAT SWITCH

(only for single-phase versions)

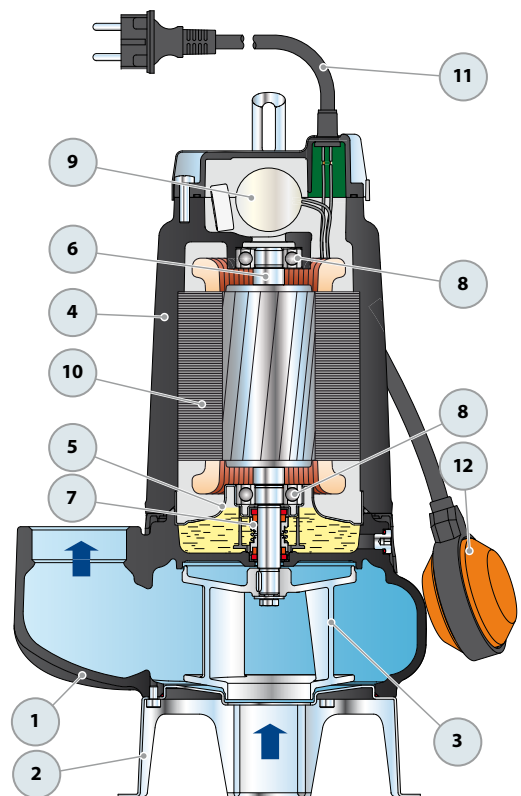

## DIMENSIONS AND WEIGHT

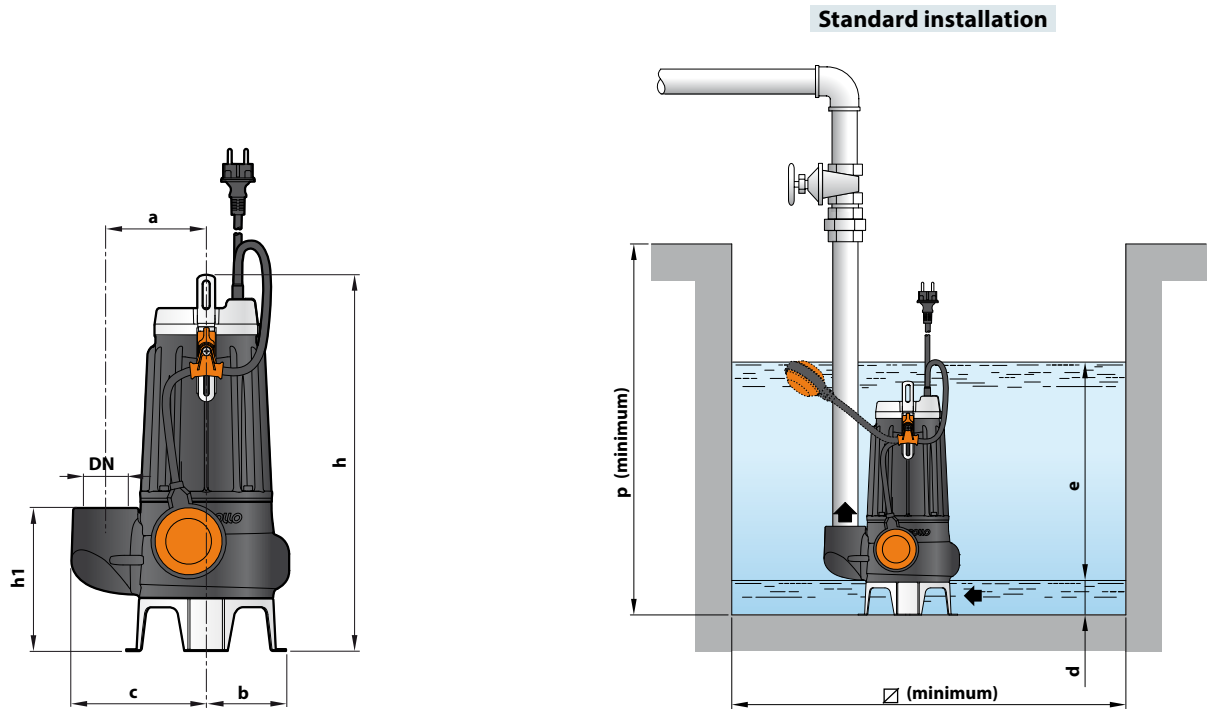

MODEL		PORT DN	Passage of solids	DIMENSIONS mm										kg	
Single-phase	Three-phase			a	b	c	h	h1	d	e	p	Ø	1~	3~	
MCm 10/45-N	MC 10/45-N	2"	Ø 50 mm	115	95	155	413	164	60	variable	500	500	19.0	17.9	
MCm 15/45-N	MC 15/45-N						428								20.2

## ABSORPTION

MODEL	VOLTAGE		
	220 V	110 V	127 V
MCm 10/45-N	5.6 A	11.2 A	10.3 A
MCm 15/45-N	8.8 A	-	-

MODEL	VOLTAGE		
	220 V	380 V	440 V
MC 10/45-N	4.2 A	2.4 A	2.1 A
MC 15/45-N	6.6 A	3.8 A	3.3 A

## PALLETIZATION

MODEL		GROUPAGE n. pumps	CONTAINER n. pumps
Single-phase	Three-phase		
MCm 10/45-N	MC 10/45-N	54	72
MCm 15/45-N	MC 15/45-N	54	72