



DISPENSERS



PUMPS



METERS



NOZZLE



FILTRATION



FLUID MONITORING

EX50 ST

FEATURES

- STURDY STRUCTURE
- COMPACT, VERSATILE
- EASY TO INSTALL
- ANTI-NOISE FILTER
- OVERLOAD PROTECTION

The PIUSI EX50 ST is a sturdy and compact transfer station equipped with an ACEX/IECEX certified pump suitable for the transfer of all flammable liquids. These transfer stations are the final solution for all applications in which mobile or underground tanks need to be equipped with a dispenser unit. Thanks to the flanged components, this transfer set allows users to replace any component without using sealants.

PERFORMANCE

UP TO
50 L/MIN

FLOW RATE

AC
VOLTAGE

POWER

± 1%

ACCURACY

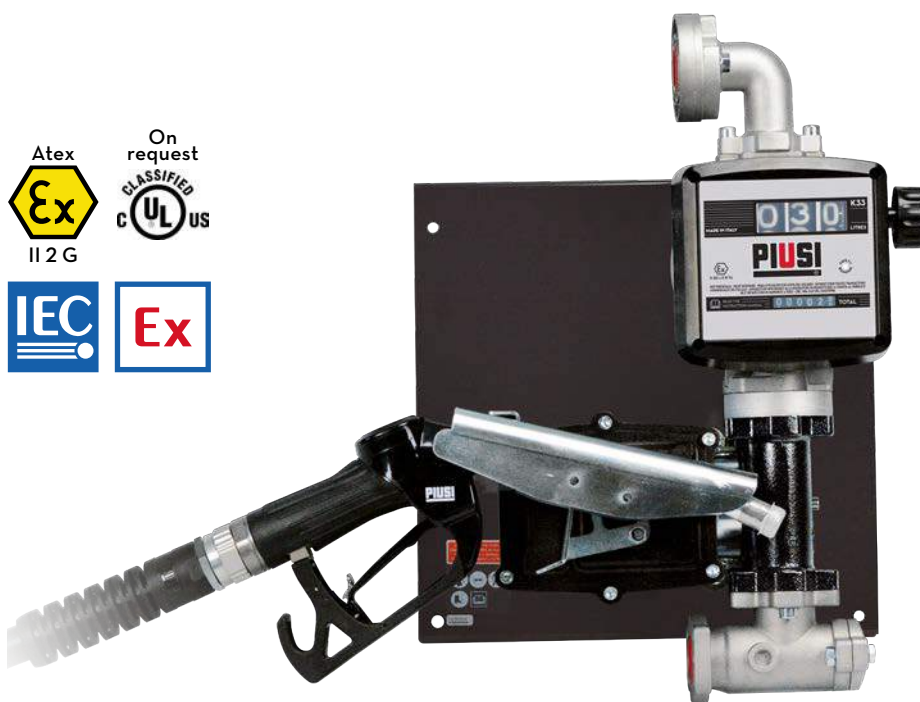

PIUSI ST EX50 WITH METER AND NOZZLE



OUR PUMPS COMPLY WITH THE FOLLOWING MARKING ATEX/IECEX

II	2	G	Ex	d	IIA	T4	Gb
GROUP	CATEGORY	TYPE OF EXPLOSIVE ATMOSPHERE	PERMANENT PREFIX	PROTECTION METHOD	GAS GLASS	TEMPERATURE CLASS	EQUIPMENT PROTECTION LEVEL

PACKAGING

CODE	WEIGHT		PACKAGING		
	KG	LBS	MM	INCH	PCS/BOX
WITH METER					
FO0377000	12	24,5	600X400X290	23,6X13,7X11,4	1



HOSE REELS



ACCESSORIES



MERCHANDISE



AIR



ANTIFREEZE

AdBlue[®]

BIODIESEL



DIESEL



FOOD



GASOLINE



GREASE



KEROSENE



OIL



WATER

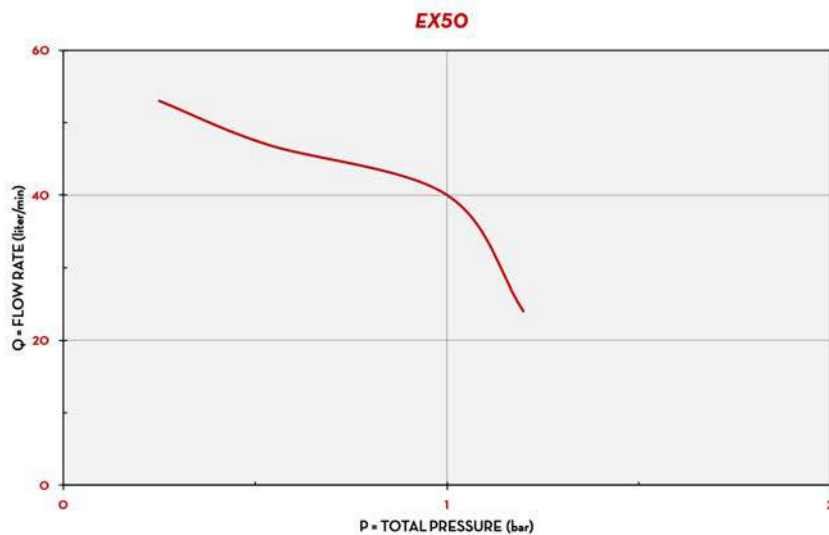

WINDSCREEN

CHART

TYPE OF FLUID DIESEL

TEMPERATURE 23 °C

IN THE BOX

- METALLIC PLATE
- EX50 PUMP
- TELESCOPIC SUCTION HOSE
- GASOLINE HOSE
- FILTER
- NOZZLE
- 2" CONNECTOR
- K33 MECHANICAL METER (ON REQUEST)
- INSTRUCTION MANUAL

COMPONENTS' DETAILS

NUTATING DISK SYSTEM

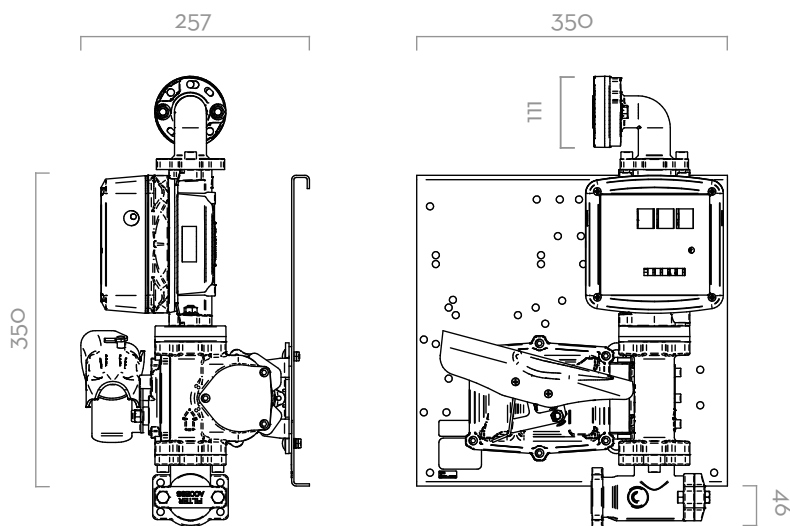

MESH STRAINER

DIMENSIONS

Dimensions expressed in millimeters

COMPONENTS

- **PUMP:**
EX50 PAG. 58
- **METER:**
K33 ATEX PAG. 90
- **NOZZLE:**
A60 ATEX PAG. 116

TECHNICAL DATA

CODE	DESCRIPTION	FLUIDS TYPE	FLOW-RATE		VOLTAGE			METER	NOZZLE	FILTER	INLET BSP	HOSE	
			L/MIN	GPM	AC V/HZ DC VOLT	POWER WATT	AMP. MAX.	TYPE	TYPE			LENGTH MM	Ø BSP
WITH METER													
FO0377000	ST EX50 230V K33 ATEX + AUT. NOZZLE	D G K	50	13	230/50-60	250	21	K33	AUT.	-	1"	4	3/4"

(*) UPON REQUEST IT IS AVAILABLE WITH DIFFERENT VOLTAGES AND 60 HZ FREQUENCY.
 COMPATIBLE FLUIDS: DIESEL, KEROSENE, PETROL, PETROL ALCOHOL MIXED MAX 15%, AVGAS 100/100LL, JET A/A1 - ASPEN 2/4

EX50 ST