



KIT LUBE



DISPENSERS



PUMPS



METERS



NOZZLE METERS



NOZZLES

# PIUSI HAND PUMP

## FEATURES

- OPTIMIZED SUCTION CAPACITY
- STURDY CONNECTOR
- HEAVY DUTY LEVER
- FLUENT REVOLUTION
- HIGH EFFICIENCY
- ADJUSTABLE SUCTION PIPE
- DURABILITY
- SELECTED MATERIALS
- 100% TESTED

The Piusi HAND PUMP is a rotary vane pump suitable for transferring low viscosity oils and diesel. Entirely designed, manufactured and certified in Italy this sturdy pump guarantees a professional performance.

## PERFORMANCE

up to

**38L/100REV**

FLOW RATE

available with

**3M**

length

DELIVERY HOSE



HAND PUMP FOR OIL-DIESEL



## PACKAGING

CODE	WEIGHT		PACKAGING			N. BOXES/ EUROPALLET	
	KG	LBS	MM	PCS/PALLET	PCS/BOX		
FO0332500	2,1	4,6	350X170X140		1	50	100



WASTE OIL EQUIPMENTS



FILTRATION



FLUID MONITORING



HOSE REELS



ACCESSORIES



MERCHANDISE

INDEX



AIR



ANTIFREEZE



AdBlue®



BIODIESEL



DIESEL



FOOD



GASOLINE



GREASE



KEROSENE



OIL



WATER



WINDSCREEN

## CHARTS

### PIUSI HAND PUMP

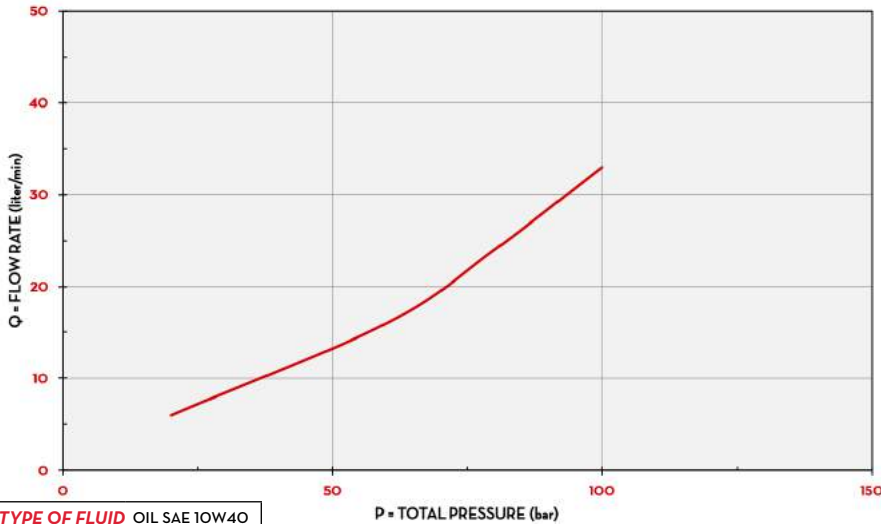

TYPE OF FLUID OIL SAE 10W40  
TEMPERATURE 23 °C

## IN THE BOX

- PIUSI HAND PUMP
- SPOUT
- INSTRUCTION MANUAL
- SUCTION PIPE
- DRUM CONNECTOR

## DETAILS



HIGH QUALITY MATERIALS



NON-SLIP HANDLE



SUCTION PIPE

## DIMENSIONS

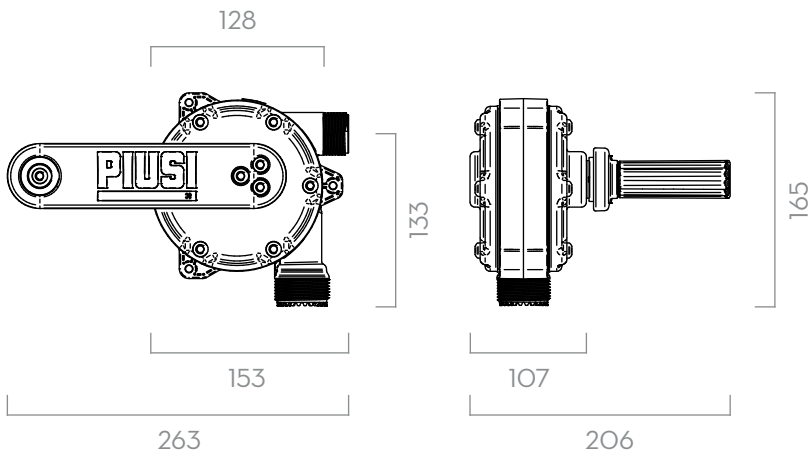

Measures expressed in millimeters

## MATERIALS

- BODY: STAINLESS STEEL, TECHNOPOLYMER
- ROTOR: TECHNOPOLYMER
- VANES: TECHNOPOLYMER

## TECHNICAL DATA

CODE	DESCRIPTION	FLUIDS TYPE	CAPACITY PER 100 REVOLUTIONS		DRUM CONNECTOR	SUCTION TUBE	"S" SPOUT AND HOSE TAIL	DELIVERY HOSE LENGHT
			L	USG				M
FO0332500	PIUSI HAND PUMP 2" BSP		38	10	2" BSP	YES	YES	-

# PIUSI HAND PUMP