



DISPENSERS



PUMPS



METERS



NOZZLE



FILTRATION



FLUID
MONITORING

K700 PULSER

FEATURES

- EASY TO INSTALL AND TO CALIBRATE
- VERSATILE
- HIGH FLOW RATE
- HEAVY DUTY
- INDUSTRIAL APPLICATIONS

The PIUSI K700 PULSER is an oval gear electronic meter with acetal resin gears. This pulse meter easily interfaces with management systems, making it the ideal solution to fit fuel distributors. It is also suitable for tanks and cisterns, loading arms controlling the consumption of fuel in burners or generator sets, besides other applications.

PERFORMANCE

25-250

L/MIN

FLOW-RATE

20 BAR

MAX OPERATING

PRESSURE

± 0,5%

ACCURACY

0,2%

REPEATIBILITY



K700 PULSER



PACKAGING

CODE	WEIGHT		PACKAGING		
	KG	LBS	MM	INCH	PCS/BOX
PULSER					
FOO49800A	5,5	12	280X160X140	11X6,3X5,5	1



HOSE REELS



ACCESSORIES



MERCHANDISE



AIR



ANTIFREEZE



AdBlue®



BIODIESEL



DIESEL



FOOD



GASOLINE



GREASE



KEROSENE



OIL



WATER



WINDSCREEN

CHART

IN THE BOX

- K700 PULSER UNIT
- INSTRUCTION MANUAL

DETAILS



INBUILT SUCTION FILTER



OVAL GEARS

MATERIALS

- BODY: ALUMINIUM
- GEARS: TECHNOPOLYMER

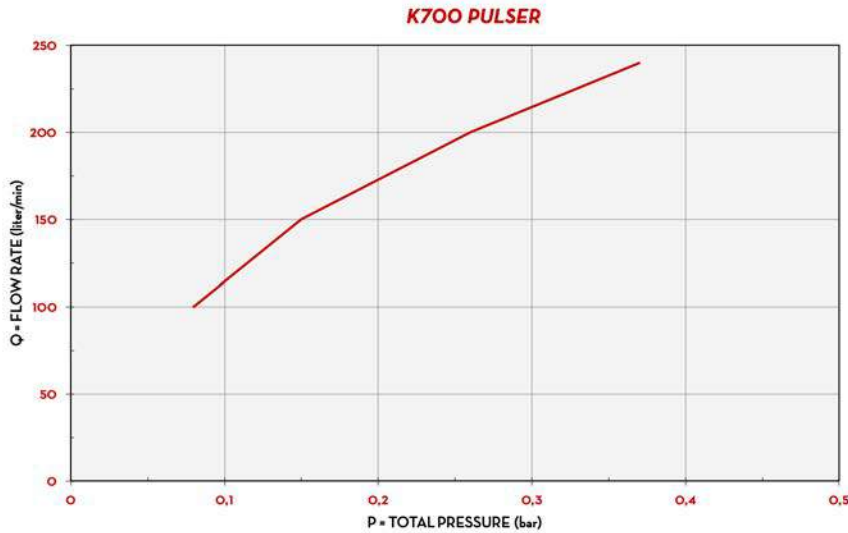

TYPE OF FLUID DIESEL
 TEMPERATURE 8 °C

DIMENSIONS

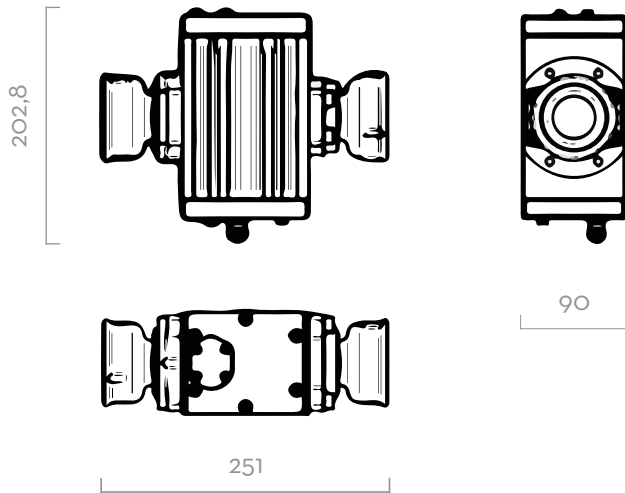

Dimensions expressed in millimeters

TECHNICAL DATA

CODE	DESCRIPTION	FLUIDS TYPE	FLOW-RATE		PULSER		PRESSURE		BATTERY N°2 X 1,5V (INCLUDED)	FLANGE	INLET / OUTLET	INLET FILTER
			L/MIN	GPM	P/L	GPM	BAR	PSI				
PULSER												
FO049800A	K700 PULSER	A B D O	25 - 250	6,6 - 66	14	53	20	300	NO	YES	2" BSP	YES

UPON REQUEST AVAILABLE IN NPT VERSION.

K700 PULSER