



KITS



PUMPS



METERS



METERED NOZZLES



NOZZLES



WASTE OIL EQUIPMENTS

# MA 140

## FEATURES

- IN/OUT SWAPPABLE
- BUILT-IN DIFFUSER
- SUITABLE FOR IMMERSED INSTALLATION
- HEAVY DUTY
- EXPLOSION PROOF (EX ZONE 2)
- EASY TO FIT
- STURDY DESIGN

The PIUSI MA 140 is a long life pneumatic diaphragm pump suitable for transferring high viscosity fluids and waste oils. The small size of this pump allows a wide range of possible installations.

### PERFORMANCE

UP TO <b>100 L/MIN</b>	MAX <b>7 BAR</b>
FLOW RATE	AIR PRESSURE
<b>6M</b> MAX CAPACITY	MAX <b>Ø 4MM</b>
SELF PRIMING	PASSING SOLID



MA 140



### PACKAGING

CODE	WEIGHT		PACKAGING			
	KG	LBS	MM	INCH	PCS/PALLET	PCS/BOX
FOO208P10	5	11	240X380X350	9,4X15X13,8		1



FILTRATION



FLUID MONITORING



TANK MONITORING



HOSE REELS



ACCESSORIES



MERCHANDISE



AIR



ANTIFREEZE



AdBlue®



BIODIESEL



DIESEL



FOOD



GASOLINE



GREASE



KEROSENE



OIL



WATER



WINDSCREEN

### CHART

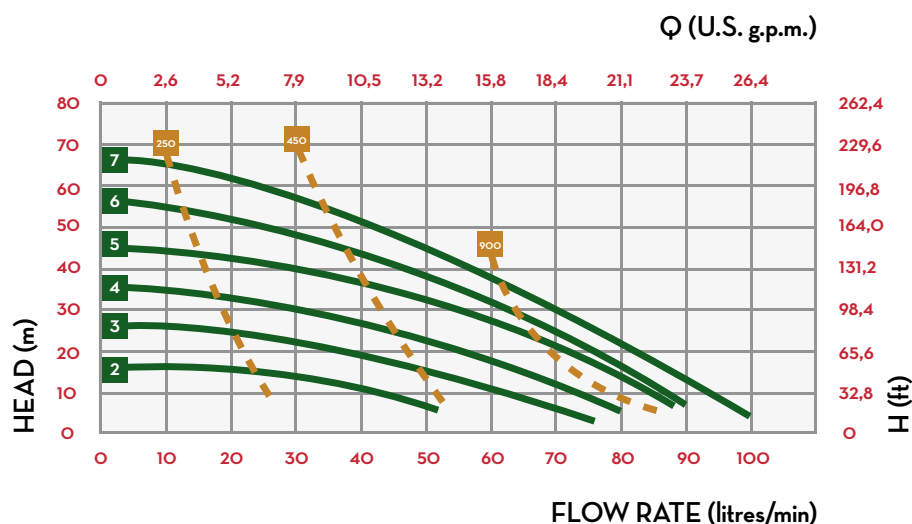

### IN THE BOX

- MA 140 PUMP
- INSTRUCTION MANUAL

### DETAILS



HEAVY DUTY MATERIALS



TECHNOPOLYMER BODY



STURDY DESIGN

### MATERIALS

- BODY: TECHNOPOLYMER
- FITTINGS: ALLUMINIUM
- DIAPHRAGMS: TECHNOPOLYMER

### DIMENSIONS

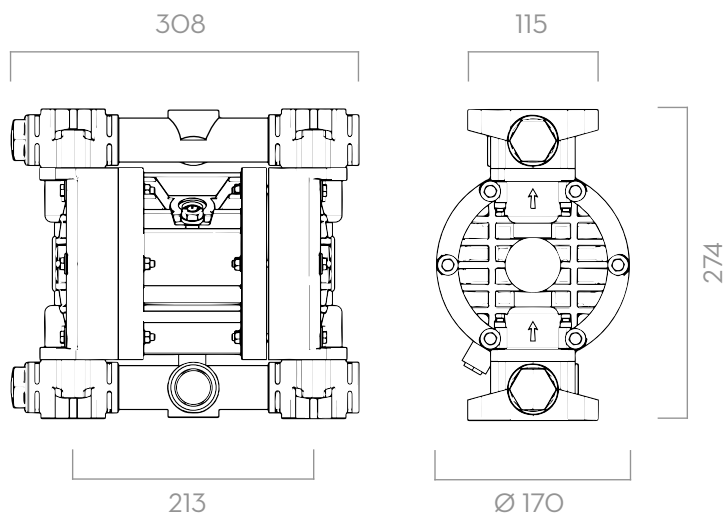

Dimensions expressed in millimeters

### TECHNICAL DATA

CODE	DESCRIPTION	FLUIDS TYPE	PUMP BODY	IN / OUT	FLOW RATE L/MIN	MEMBRANE TYPE	DIAPHRAGM	BALLS	BALL SEATS*	O-RING*	INTAKE / DELIVERY CONNECTION	AIR CON. CONNECTION	MAX SELF-PRIMING CAPACITY M	MAX HEAD** M	MAX AIR SUPPLY PRESSURE BAR	MAX Ø OF PASSING SOLID MM
FOO208P10	PIUSI MA 140		POLYPROPYLENE	1" G	100	SINGLE	NBR	NBR	POLYPROPYLENE	NBR	G 1" F	G 3/8" F	6	70	7	4

(\*) ON REQUEST WE CAN PROVIDE MEMBRANES, BALLS, BALL SEATS AND O-RINGS IN DIFFERENT MATERIALS.  
 (\*\*) THE VALUE DEPENDS ON THE CONFIGURATION OF THE PUMP

# MA 140