



KIT LUBE



DISPENSERS



PUMPS



METERS



NOZZLE METERS



NOZZLES

NEXT/2

FEATURES

- ADJUSTABLE UNIT OF MEASUREMENT
- EASY BATTERIES MAINTENANCE
- AAA STANDARD BATTERY
- SHOCK-ABSORBING PROTECTION
- ON-SITE CALIBRATION

The Piusi NEXT/2 meter is an oval gear meter suitable for the delivery of low, medium and high viscosity oils. Its particular size allows the meter to count at high flow rates.

PERFORMANCE

up to

60 L/MIN

(up to 7,8 gpm)

FLOW RATE

± 0,5 %

ACCURACY

0,2%

REPEATABILITY

max

70BAR

PRESSURE



NEXT/2



PACKAGING

CODE	WEIGHT		PACKAGING			
	KG	LBS	MM	INCH	PCS/PALLET	PCS/BOX
FOO486150	0,6	1,3	115X160X135	4,5X6,3X5,3		1



WASTE OIL EQUIPMENTS



FILTRATION



FLUID MONITORING



HOSE REELS



ACCESSORIES



MERCHANDISE

INDEX



AIR



ANTIFREEZE



AdBlue®



BIODIESEL



DIESEL



FOOD



GASOLINE



GREASE



KEROSENE



OIL



WATER



WINDSCREEN

CHARTS

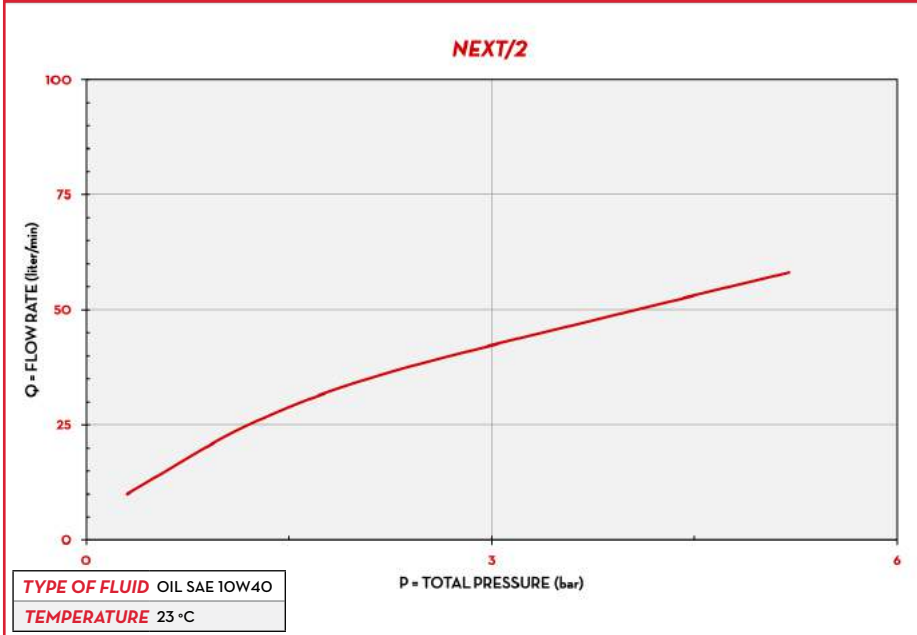

IN THE BOX

- NEXT/2 METER
- INSTRUCTION MANUAL

DETAILS



RESET BUTTON



OVAL GEAR



2 AAA BATTERIES INCLUDED

MATERIALS

- BODY: ALLUMINIUM
- GEARS: TECHNOPOLYMER

DIMENSIONS

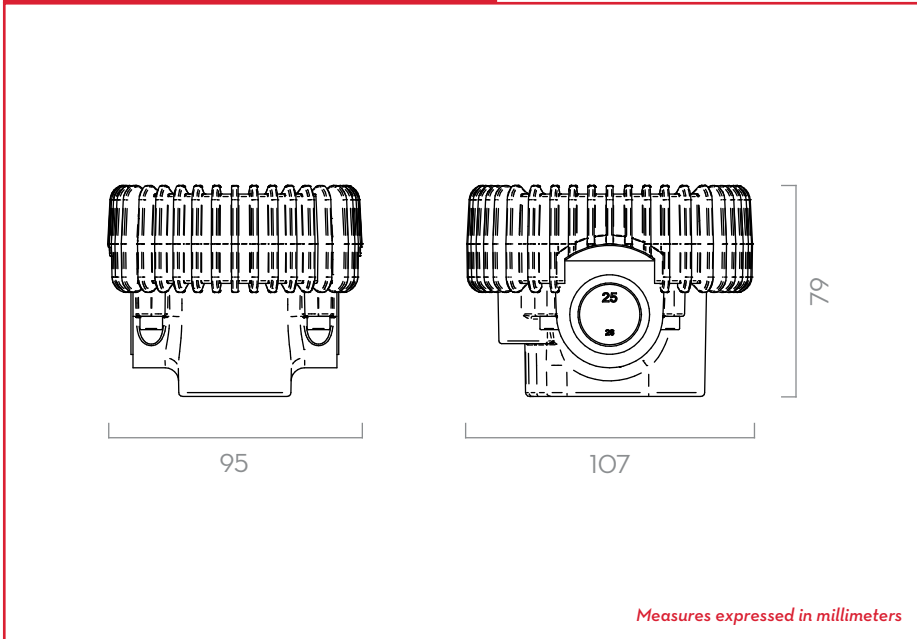

TECHNICAL DATA

CODE	DESCRIPTION	FLUIDS TYPE	FLOW-RATE		WORKING PRESSURE		BATTERY INCLUDED AAA N°2 2X1,5 V	INLET	OUTLET
			L/MIN	GPM	BAR	PSI			
FOO486150	NEXT/2		6 - 60	1,58 - 158	70	994	YES	3/4" BSP	3/4" BSP

NEXT/2