

The PIUSI logo is located in the top left corner. It consists of the word "PIUSI" in a bold, white, sans-serif font, with a registered trademark symbol (®) to its right. The logo is set against a dark background with a white horizontal line underneath the text.

PIUSI®

The background of the advertisement is a photograph of a person's hands, wearing a dark sleeve and a grey glove, holding a metal fuel nozzle. The nozzle is connected to a hose and is positioned near a metal grate. The scene is dimly lit, with a strong light source from the right, creating a dramatic effect. The overall color palette is dark with yellow and white accents.

OFF ROAD EQUIPMENT

> The complete range of solutions to manage heavy duty vehicles refueling



CHOOSE THE BEST REFUELING SOLUTION FOR YOUR OFF ROAD VEHICLES WHEREVER YOU NEED IT.

PIUSI goes "off road" with its complete range of solutions suitable to manage any kind of vehicle refueling in every situation; from fixed to mobile and on board systems.

All the pumps and dispensers are specifically engineered to meet the demand for daily use in the building & construction industry, mining sector and agricultural field.

- **Tailor made:** to suit all the OEM needs;
- **Partnership:** co-design with customers' R&D department aimed to develop new products and solutions to meet the required standard;
- **Flexibility and reliability:** mobile, on board and stationary refueling equipment to suit every application;
- **Cost and time efficiency:** thanks to the possibility of a quick refueling operation wherever needed;
- **Fully compliant:** Tier 4 IIIB engines whether you use SCR, DPF or EGR systems (B20 versions).

Are you ready for the future?

Go off road with PIUSI's range!



> YOUR NEEDS, OUR SOLUTION

APPLICATION 01



State-of-the-art pumps to satisfy the requirements for the **on board refueling** on heavy equipment and earthworks machinery.



> ON BOARD REFUELING

APPLICATION 02



Powerful and portable equipment, easy to handle, that allows refueling operations on-site in cases where reaching the refueling area is not simple.

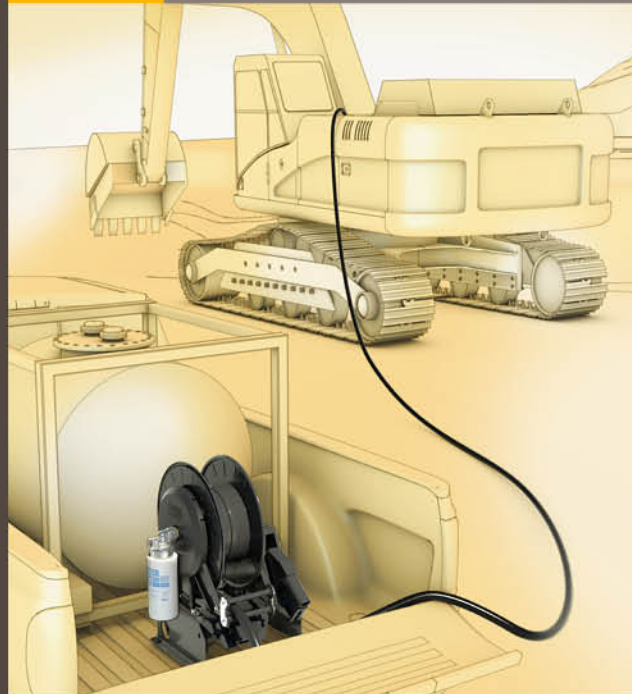

> MOBILE REFUELING

APPLICATION 03



When **high flow** is required, this equipment is suitable for operating directly on worksites and on vehicles with large storage tanks.

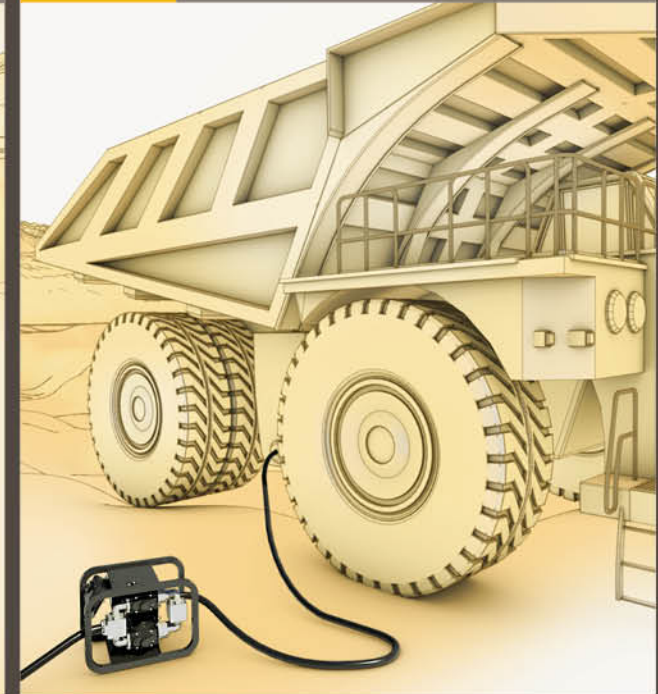

> HIGH FLOW REFUELING

The mobile and fixed solutions easily suit a wide variety of applications: a new and easy way to automatically and safely manage refueling operations of earthmoving machines, heavy duty vehicles and OEM equipment.

APPLICATION 04



The complete range of fixed dispensers to set up a refueling area for any vehicle tank on the working site.

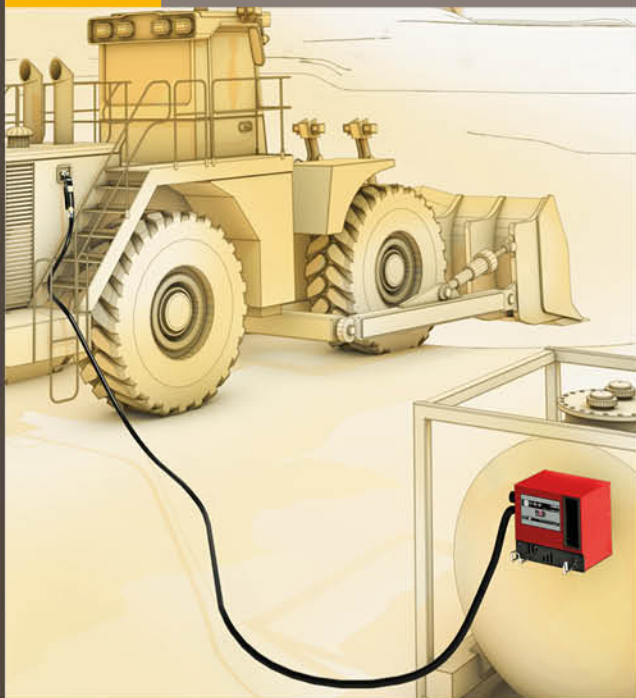

> **FIXED REFUELING**

APPLICATION 05



A complete range of explosion proof equipment suitable for refueling operation in a potentially explosive atmosphere.

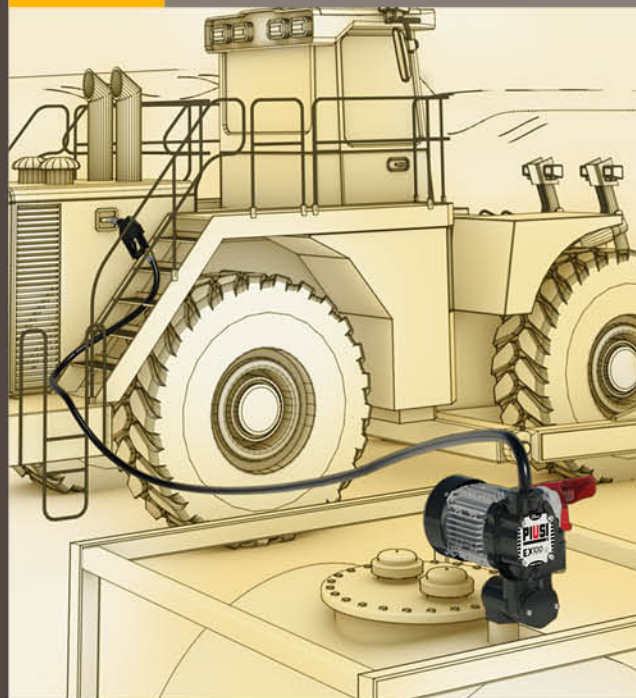

> **EXPLOSION PROOF EQUIPMENT**

APPLICATION 06



Dedicated AdBlue® equipment both for high and low consumptions according to plant requirements.



> **AdBlue® EQUIPMENT**

> OFF ROAD EQUIPMENT RANGE

MOBILE REFUELING

Engineered to allow all refueling operations on the worksite.

> PAGES 16 / 19

FIXED REFUELING

Dispensers for fixed installations on tanks or drums.

> PAGES 24 / 29

ON BOARD REFUELING

Top-technology pumps with integrated "intelligence system" for any on board application.

> PAGES 8 / 15

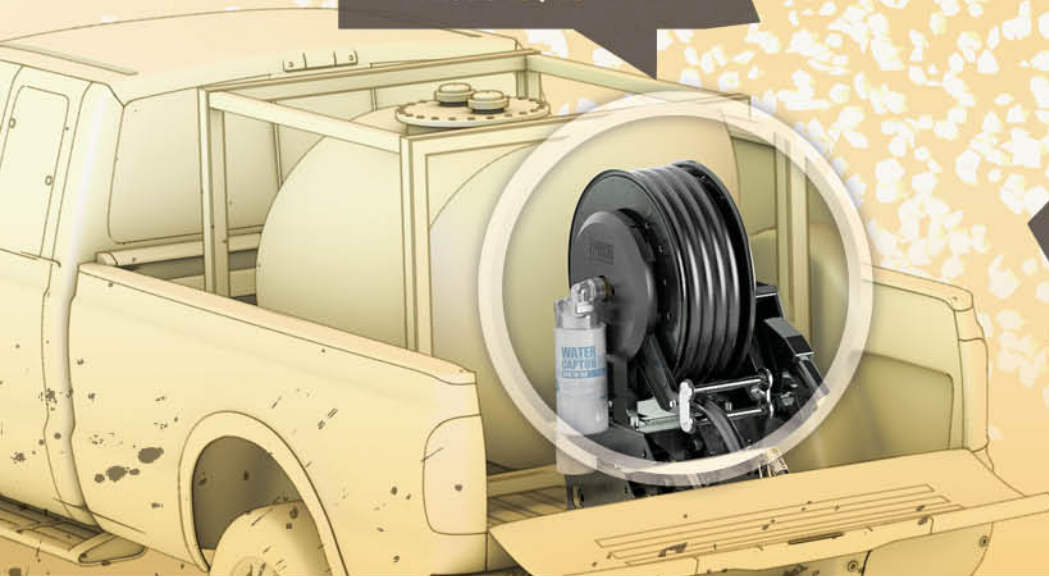
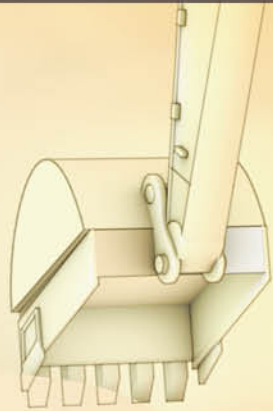

**EASY TO USE, TAILOR MADE AND SUITABLE FOR ALL SITUATIONS:
PIUSI RANGE OF EQUIPMENT FOR OFF ROAD APPLICATIONS IS THE CHOICE
FOR EARTHMOVING, FARMERS AND MINING CONTRACTORS.**

**AdBlue®
EQUIPMENT**

Special equipment for AdBlue® transferring for any consumption requirements.

> PAGES 34 / 37

ACCESSORIES

Professional accessories to complete the off road equipment range

> PAGES 32 / 33

**HIGH FLOW
REFUELING**

The perfect solutions for the most demanding flow requirements.

> PAGES 20 / 23

**EXPLOSION PROOF
EQUIPMENT**

Dedicated equipment suitable for refueling operation in a potentially explosive atmosphere.

> PAGES 30 / 31

ON BOARD

REFUELING



TAILOR MADE AND CUSTOMIZED TOP-IN-LINE SOLUTIONS FOR ANY OEM MACHINERY.

A complete range of DC pumps suitable to meet the highest demand for service and quality. Vantage is a range of **intelligent pumps** that can monitor their own activity adapting the flow-rate and stopping automatically according to the vehicle tank.



> BP 3000

This long-lasting vane pump is equipped with a built-in by-pass valve. Available in both 12V and 24V versions, it represents the core of the on board range.

DIESEL



FLOW-RATE
up to **50** l/min at 0.25 bar

- Max differential pressure 1.0 bar
- 30 minutes duty time
- Self priming up to 3 meters depth
- Cast iron pump body
- Anti-corrosion finishing
- Sintered steel rotor and acetal resin vanes

BP 3000 INLINE



> BP 3030

This DC pump maintains all the main structural features of the BP 3000 while being specifically engineered to be compatible with B30 Bio Fuel and Tier 4 III B engines. The BP 3020 version is compatible with B20 Bio Fuel.

B30 DIESEL

B20 DIESEL

DIESEL



FLOW-RATE
up to **50** l/min at 0.25 bar

- Max differential pressure 1.0 bar
- 30 minutes duty time
- Self priming up to 3 meters depth
- Resistant to dry running
- Cast iron pump body
- E-coat finishing on the whole body
- Mechanical seals
- PPS Vanes
- Thermally protected motor

BP 3030 INLINE





> VANTAGE 60

DIESEL

Smart fuel pump, available both in 12V and 24V versions, it can be installed on any vehicle thanks to its customized elements. Its intelligent control box guarantees a fully automatic performance in terms of self-refueling and overheating regulation.



FLOW-RATE

up to **60** l/min at 0.25 bar

- Max differential pressure 1.0 bar
- Self priming up to 3 meters depth
- Incorporated by-pass valve
- Operation status LED
- Removable control box



> VANTAGE 3020

B20 DIESEL

DIESEL

High performance and environment friendly pumps, the 3020 series perform all features of Vantage 60 while being fully compatible with Tier 4 IIIB engines and biodiesel B20.



FLOW-RATE

up to **60** l/min at 0.25 bar

- Max differential pressure 1.0 bar
- Self priming up to 3 meters depth
- Cast iron pump body
- E-coat finishing on the whole body
- Mechanical seal
- PPS Vanes
- Thermally protected motor
- Removable control box





VANTAGE 100

Top-in-line vane pump with rotor specifically designed for on board refueling of heavy duty vehicles with tank capacity exceeding 400 liters. The pump is Tier 4 III B compatible and can transfer ultra-low-sulfur-diesel "ULSD" and biodiesel B20.



FLOW-RATE

up to **100** l/min at 0.25 bar

- Tension 24V DC
- Cast iron pump body
- E-coat finishing on the whole body
- Mechanical seals
- DPS Vanes
- Thermally protected motor
- Removable control box



VANTAGE DC INTELLIGENT PUMP



Discover here the Vantage intelligent system in all the different conditions.

A / Switches off after 15 minutes

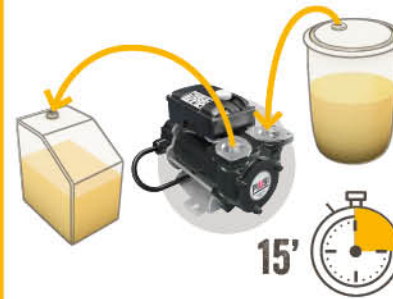

B / Dry running: detects this condition and shuts down the pump



C / Stops when the tank is full



D / Overheating and overpressure: reduces power and allows refueling at a slower rate





> TAILOR MADE SOLUTIONS

Each customer has his unique requirements. Thanks to our R&D department, we can supply highly “made to measure” co-designed solutions that meet both the customers' as well as the industry's specific needs.

Starting from the top-quality standard BP 3000 and Vantage range, PIUSI can design, create and industrialize the perfect solution in terms of connections, valves, base and cables.



01 / CONNECTIONS

Wide range of heavy duty connectors.

Features:

- Different sizes and shapes
- Heavy duty
- Co-designed on customers' requests

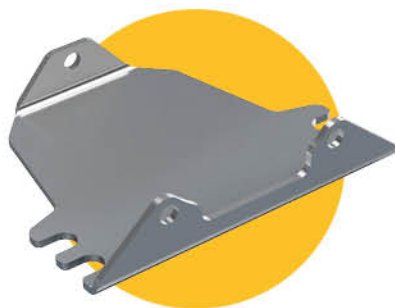

02 / SUPPORT

Custom designed pump support bracket to perfectly suit all vehicles.

Features:

- High-resistance support
- Maximum stability and correct fixing
- Co-designed on customers' requests





03 / ELECTRIC CONNECTIONS

Customized electric plug.

Features:

- Long lasting pin
- Sturdy cable jacket



04 / FOOT VALVE

A new concept of valve for fuel suction hoses on machinery.

Features:

- Mesh filter for diesel fuel residues
- Anti shock materials to avoid damage caused by dropping
- Low pressure drop





> TESTING

This range of pumps, expressly engineered to be used on the OEM machines, are 100% tested accordingly to the following inspections.

These wide range of mechanical and electronic tests are carried out on all components to guarantee the maximum reliability and long-lasting equipment.

Type of test:	Test document reference:
01 > HIGH TEMPERATURE TEST	Our Ref. test PIUSI Rdp 1742
02 > LOW TEMPERATURE TEST	Our Ref. test PIUSI Rdp 1742
03 > HIGH TEMPERATURE STORAGE TEST	Our Ref. test PIUSI Rdp 1742
04 > LOW TEMPERATURE STORAGE TEST	Our Ref. test PIUSI Rdp 1742
05 > VIBRATION TEST	Our Ref. CERMET 2011_OO172
06 > TEMPERATURE HUMIDITY CYCLE	Our Ref. test PIUSI Rdp 1742
07 > THERMAL SHOCK TEST	Our Ref. REGGIO EMILIA INNOVAZIONE O1 2010
08 > MECHANICAL SHOCK TEST	Our Ref. REGGIO EMILIA INNOVAZIONE PSO10411ENDEO571
09 > WATER PROOF RESISTANCE	Our Ref. RES 80746
10 > DUST PROOF RESISTANCE	Our Ref. RES 80746
11 > SUPPLY VOLTAGE TEST	Our Ref. test PIUSI Rdp 1742
12 > EMC TEST	Our Ref. REGGIO EMILIA INNOVAZIONE PSO40511EMCO571
13 > DURABILITY TEST	Our Ref. PIUSI Rdp 1742
14 > SALT SPRAY TEST	Our Ref. CERMET 2011_OO255



**WE DON'T FEAR
ANY CONDITION**



MOBILE REFUELING



MOVE YOUR FUEL TRANSFER SYSTEM WHEREVER NEEDED.

A complete range of dispensers that allow to bring the refueling system in every area on the worksite. Thus it is **not necessary** to move the **OEM machinery** to a dedicated area for a valuable time-saving.



> PITSTOP

Dispenser unit with two DC pumps, hose reel, water filter and automatic nozzle integrated in a sturdy supporting structure. Versatile and compact, this dispenser is the all-in-one solution for setting up a perfect mobile refueling unit.

DIESEL



EXAMPLE OF MOBILE INSTALLATION



FLOW-RATE

up to **45** l/min

- Two BP 3000 pumps 12/24V
- 30 minutes duty time
- Hose 3/4" - 14 m (1" - 10 m).
- Filter with water absorption cartridge
- Sturdy metallic structure
- Hose reel side safety guards
- Adjustable arms with end-of-travel hose stop
- ON/OFF switch
- K24 meter (on request)

> PIUSIBOX

Portable box integrated with a self-priming transfer pump, filter, check valve and manual nozzle suitable for quick and safe refuel operations in all the situations where an easy mobile refueling is required.

DIESEL



EXAMPLE OF DRUM APPLICATION



FLOW-RATE

up to **45** l/min

- BP 3000 pumps 12/24V
- 30 minutes duty time
- Integrated filter (PRO version)
- Rotating connection
- ON/OFF switch
- Foot valve
- K24 meter (on request)
- Easy to repack after use



BATTERY KIT

Portable diesel transfer unit with a self-priming electric vane pump. Its modular composition allows to have different pumps accordingly to the required flow-rates and different usages. It is always supplied with integrated nozzle and a set of accessories.

DIESEL

OIL



FLOW-RATE

up to **80** l/min*

- 12/24V DC pumps
- 30 minutes duty time
- Self priming up to 2 meters
- Cast iron body
- Fixed brush motor with permanent magnet stator
- Terminal board with switches and fuses to protect against overload
- ON/OFF switch
- Drum kit (on request)

*Depending on pump model

KIT WITH AVAILABLE PUMPS

• Battery Kit 3000 INLINE



• Battery Kit PANTHER



• Battery Kit 3000 BIPUMP



• Battery Kit OIL





ALL WORKSITES AND ENVIRONMENTS ARE OK FOR REFUELING WITH PIUSI'S MOBILE SOLUTIONS: WE DON'T FEAR ANY EXTREME CONDITION!



HIGH FLOW

REFUELING



**PERFECT EQUIPMENT
FOR HIGHEST REQUIREMENTS.**

These high performance dispensers **have been expressly designed and engineered** to meet the requirements of OEM machineries, earthmoving vehicles and tractors which need high flow for refueling.



> ST 200 AC

DIESEL

This dispenser allows high flow refueling thanks to the two integrated E120 self priming rotary electric vane pumps. Fitted with by-pass valve and elevated reliability seal, the dispenser works even at low working temperatures and in every condition on worksites.



FLOW-RATE

up to **200** l/min

- AC 230V
- Continuous duty
- Sturdy steel frame
- Wheels and handle available as accessories
- Suction hose up to 10 m
- Flow-rate up to 170 l/min with 20 m hose length (hose kit 1" 1/2)
- Self priming



HANDY KIT:
version with wheels and handle

> ST 200 DC

DIESEL

24V portable dispensing unit for high flow applications. The low weight of the unit makes it easy to handle and suitable for operating on worksites.

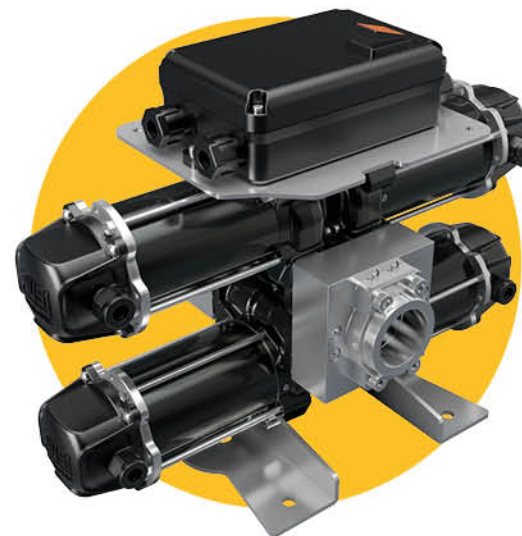

FLOW-RATE

up to **185** l/min

- 20 minutes duty time
- Thermal protection
- Suction hose up to 10 m
- Flow-rate up to 170 l/min with 20 m hose length (hose kit 1" 1/2)
- Self priming



> E140

This volumetric, self-priming vane pump is versatile, easy to install and suitable for use inside diesel dispensers and for fixed fuel transfer systems.

Thanks to its sturdy structure, it is fully reliable even at low temperatures.



FLOW-RATE

up to **140** l/min

- AC version
- Heavy duty applications
- High flow-rate
- ON/OFF switch



DIESEL

> E300

With a flow-rate of up to 550 l/min*, this self-priming electric pump with open impeller is suitable for all applications in which high flow-rates are required.

Thus, it is the ideal equipment for topping up and transferring diesel from all kinds of tanks.



FLOW-RATE

up to **550** l/min*

- AC continuous duty
- Max operation pressure 1.8 bar
- Open impeller

*Nominal flow-rate without automatic nozzle

DIESEL

A high-angle, close-up photograph of a yellow excavator bucket digging into a trench. The bucket is filled with brown soil, and the surrounding ground shows deep tire tracks. The excavator's arm and part of the cab are visible on the right side of the frame.

**TOUGH ENOUGH
TO ASSURE
THE HIGHEST FLOW-RATE
IN EVERY SITUATION**

FIXED REFUELING



STATIONARY EQUIPMENT FOR YOUR REFUELING AREA.

Fixed dispensers, both on drums, tanks and stand alone, designed with a sturdy structure for different applications from the lower to the higher requirements in terms of number of refueling operations and flow-rate.



> DRUM

This is a modular diesel and oil transfer unit for non-commercial use that can be easily installed on drums thanks to a quick 2" coupling. It is available in different versions according to the type of pump required.

DIESEL

OIL

AVAILABLE PUMPS

● AC pump PANTHER 56



● AC pump VISCOMAT 70/200

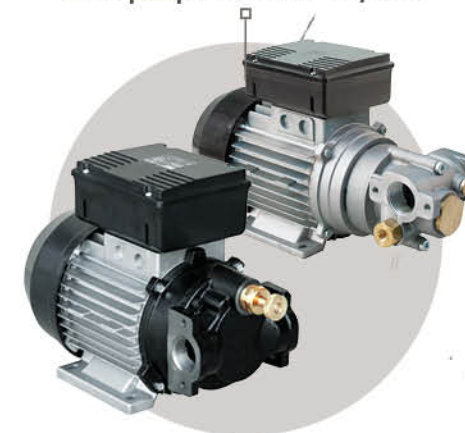

● DC pump BIPUMP



● DC pump VISCOMAT DC



FLOW-RATE

up to 80 l/min*

- AC/DC versions
- 4 meters delivery hose
- Self priming
- Telescopic suction tube
- Nozzle holder above the drum for easy & clean operations
- Quick drum connection
- Suction filter accessible for inspection

*Depending on pump model



IP 55
IP Protection
Guaranteed





> ST

Diesel transfer station that can be used to fill mobile tanks or interact with distribution units. Its sturdy structure makes this dispenser suitable to be used in the harshest environments. It can be integrated with a protective metal box and water separating filter.



FLOW-RATE

up to **90** l/min*

- AC/DC versions
- Check valve
- Filter and nozzle support
- 4 meters delivery hose (6 meters on request)

**Depending on pump model*



> ST WITH METER

Diesel transfer station for fixed installations composed by AC or DC pump, nozzle (manual or automatic) and precision meter - both mechanical (K33) or electronic (K600/3 B) - for safe and controlled refueling operations.



FLOW-RATE

up to **90** l/min*

- Accuracy +/- 1%
- AC/DC versions
- Check valve
- Filter and nozzle support
- 4 meters delivery hose (6 meters on request)
- Safety box available

**Depending on pump model*





> ST WITH METER AND FILTER DIESEL

This range of dispensers is particularly indicated for all applications in which a filtration is required.

The stations integrate PIUSI clear or water captor filters and are available both with mechanical meter K33 or electronic meter K24.

FLOW-RATE

up to 85 l/min*

- Accuracy +/- 1%
- AC version
- Check valve
- Filter and nozzle support
- 4 meters delivery hose (6 meters on request)

*Depending on pump model



> ST BOX DIESEL

A diesel refueling station complete with pump, flow meter and filter, with lockable metal protection box.

The unit is complete with antistatic hose for diesel fuel and automatic dispensing nozzle. The Pro version features the electronic access control box Access 85.

FLOW-RATE

up to 85 l/min*

- Accuracy +/- 1%
- AC version
- Check valve
- Water captor filter
- 6 to 8 meters delivery hose
- Access control

*Depending on pump model





> CUBE 56

Diesel dispenser for non-commercial use. The sturdy structure is designed for different applications: can be fixed to walls, tanks, cisterns, drums, special pedestals. It features a self-priming vane pump fitted with by-pass, installed on anti-vibration supports.

DIESEL



FLOW-RATE

up to **56** l/min

- Accuracy +/- 1%
- AC/DC versions
- Mechanical seal
- Induction motor with thermal overload protection
- Integrated nozzle holder with stop/start pump lever
- Mesh filter

IP 55
IP Protection
Guaranteed

> CUBE 70

This diesel dispenser is available both AC and DC versions and features all the main characteristics of the Cube 56 while featuring a higher flow rate. It is also available with filter.

DIESEL



FLOW-RATE

up to **70** l/min

- Accuracy +/- 1%
- AC/DC versions
- Mechanical seal
- Induction motor with thermal overload protection
- Integrated nozzle holder with stop/start pump lever
- Mesh filter

IP 55
IP Protection
Guaranteed



> CUBE 90

Top-in-line of mechanical Cube dispensers in terms of flow-rate, CUBE 90 is available in AC version only and features all the main characteristics of the CUBE range in terms of sturdy structural elements and applications.

DIESEL



FLOW-RATE

up to **90** l/min

- Accuracy +/- 1%
- AC/DC versions
- Mechanical seal
- Induction motor with thermal overload protection
- Integrated nozzle holder with stop/start pump lever
- Mesh filter

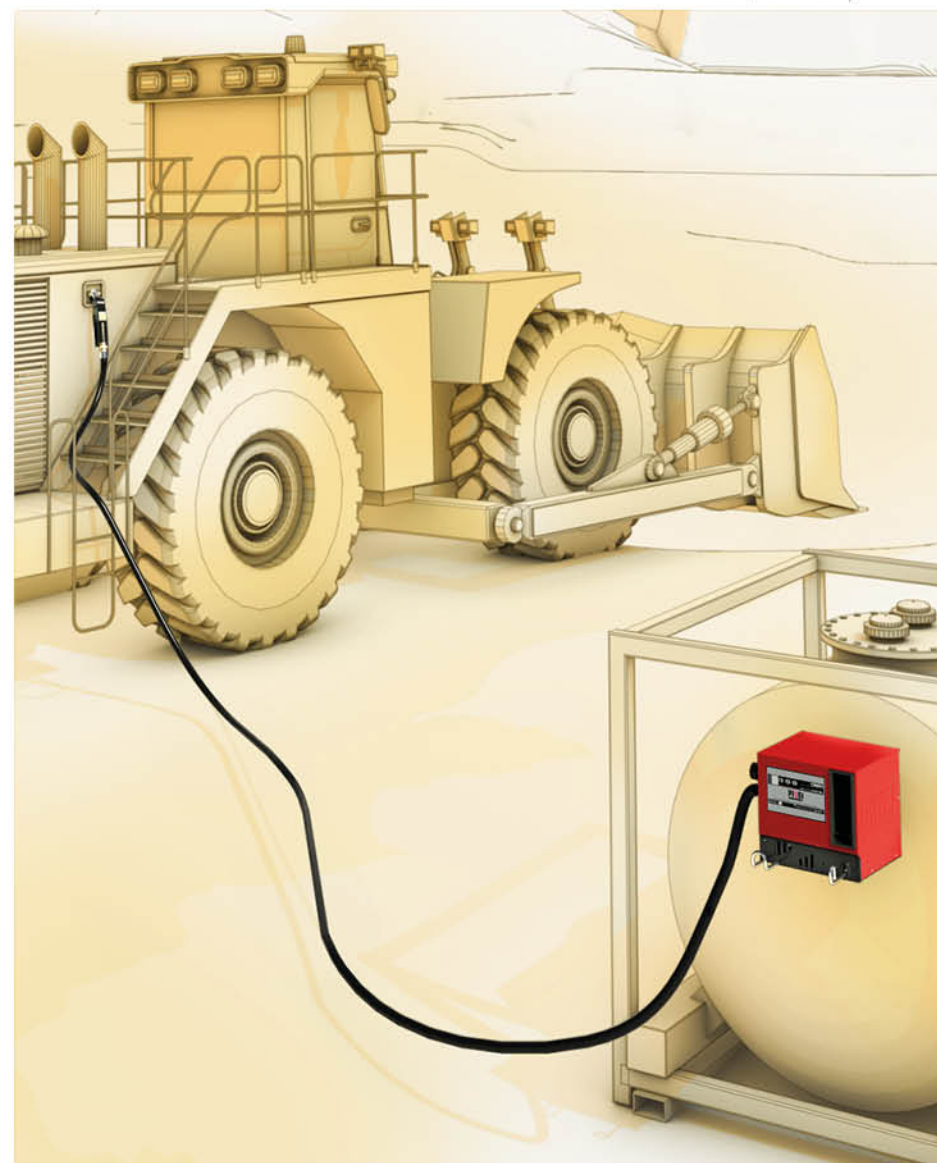

EXPLOSION PROOF EQUIPMENT

**MAXIMUM SAFETY AND HIGH PERFORMANCE
IN POTENTIALLY EXPLOSIVE ATMOSPHERES
AND WITH FLAMMABLE FLUIDS.**

A range of pumps (available in stand alone or drum versions) with **ATEX and UL certifications** engineered for heavy duty uses and suitable for transferring gasoline, kerosene and diesel fuel while guaranteeing the maximum safety and a constant flow-rate, even in complex systems.



> EX100

This highly performing pump is particularly suitable for heavy duty applications, i.e. for the most demanding fleets that need to dispense fuels such as gasoline, diesel or kerosene quickly and safety.

DIESEL

GASO-LINE

KERO-SENE

FLOW-RATE

up to **100** l/min

- Thermally protected motor
- AC continuous duty
- ATEX/cULus certified
- Constant flow-rate even in complex systems



EX100 DRUM

> EX140

This AC continuous duty transfer pump is engineered to transfer gasoline and diesel quickly while ensuring high performance and maximum safety in potentially explosives atmospheres.

DIESEL

GASO-LINE

KERO-SENE

FLOW-RATE

up to **140** l/min

- Thermally protected motor
- AC continuous duty
- ATEX/cULus certified
- Constant flow-rate even in complex systems



EX140 DRUM



> Our pumps complies with the following marking ATEX/IECEx:

II	2	G	Ex	d	IIA	T4	Gb
Group	Category	Type of explosive atmosphere	Permanent prefix	Protection method	Gas glass	Temperature class	Equipment protection level

ACCESSORIES

SPECIAL EQUIPMENTS.

The full range of off road products is completed with **professional accessories** for connecting products, filtering and delivery fluids to enhance and better suit every requirement.

> FILTROLL

Double filter, triple control. This filtering unit provides double filtering for oil and diesel fuel and absorbs any water and impurities. The unit features a supply and suction pipe with integrated bottom valve.

DIESEL

OIL

OPERATING PRESSURE

up to **15** bar

- Two step filtration
- AC/DC versions
- Filtering capacity: first stage 30µ with water absorption / second stage 5µ for impurities
- Sturdy wheeled structure
- Large-diameter wheels



> HOSE REELS

The automatic hose reels for diesel and oil have been designed to ensure high efficiency in the off road sector. The sturdy structure can guarantee the best performance also in heavy duty conditions.

DIESEL

OIL

HOSE LENGTH

up to **20** m

- Reduced pressure loss
- Rotating support plate
- Adjustable arm positions
- Hose stop
- Lateral protective covers



AdBlue®

EQUIPMENT



THE MOST INNOVATIVE SOLUTIONS FOR AdBlue®.

A complete range of pumps and dispensers expressly engineered to transfer AdBlue® from IBC containers or drums into vehicle tanks. Materials and mechanical components, designed according to the strictest requirements of ISO 22241 Standard, prevent fluid contamination for a safe and reliable operation.





> SUZZARABLU 3 BASIC/PRO AdBlue®

AdBlue® turnkey dispensing system for IBC tanks suitable for all working conditions. Available in AC/DC version, it is equipped with the SUZZARABLU pump, the 3D FILTER (in the PURE versions) and an automatic or manual nozzle. The PRO version includes the K24 meter for AdBlue® or the SB325_X METER metered nozzle.



FLOW-RATE
up to **35** l/min

- 20 minutes duty time
- AC/DC versions
- 6 meters delivery hose
- Accuracy +/- 1%*
- 3D FILTER optional
- Integrated nozzle (automatic/manual)
- Steel support and ergonomic bracket system
- Several IBC connections available (SEC/AF2/EXTERNAL SUCTION)

*SUZZARABLU 3 PRO versions

> SUZZARABLU DRUM AdBlue®

AdBlue® dispensing system provided with a stainless steel adjustable base that allows it to be moved easily from one drum to another.



FLOW-RATE
up to **32** l/min

- 20 minutes duty time
- AC/DC versions
- 6 meters delivery hose
- ON/OFF switch
- Stainless steel base
- AF2 connection



> PIUSI HAND PUMP AdBlue®

Stainless steel rotary hand pump certified for an easy and immediate transfer of AdBlue®. Its manufacturing tolerances, along with wear-resistant materials, guarantee many years of perfect operation.



FLOW-RATE
up to **38** l/ 100 revolutions

- 2,5 meters delivery hose
- Sturdy construction
- Suction hose and bung adapter

> PIUSI BOX FOR AdBlue® AdBlue®

Portable AdBlue® dispenser designed to perform quick & clean AdBlue® transfer and filling operations, when environmental conditions may be among the leading causes of fluid contamination.



FLOW-RATE
up to **35** l/min

- Duty time 20 minutes ON/ 20 minutes OFF
- DC versions
- 6 meters delivery hose
- Self priming pump
- 2 meters suction hose
- SEC connections
- 3D filter

IN THE BOX

- PUMP WITH CLAMPS
- SEC CONNECTOR
- 3D FILTER
- AUTOMATIC NOZZLE





**OUR AdBlue® EQUIPMENT
SUITS EVERY SITUATION:
FROM LOWER TO HIGHER
CONSUMPTION LEVELS**

OFF ROAD RANGE: THE PERFECT SOLUTION FOR EVERY NEED!

The off road range is available worldwide through a professional network of authorized dealers.

Get in touch
with our local
partner to order
your dispenser
or contact PIUSI
for further
information.





PIUSI
®

 [piusi.com](https://www.piusi.com)

PIUSI®

MADE IN ITALY

piusi.com

PIUSI S.p.A. • 46029 Suzzara (Mantova) Italy
tel. +39 0376 534561 • fax +39 0376 536393 • piusi@piusi.com

piusiusa.com

PIUSI USA, Inc. • 3901 Anglers Ave Fort Lauderdale; FL 33312
tel. 954 584 1552 • fax 954 584 1554 • piusiusa@piusiusa.com

11.20 • EN