



CAR FILLING



DISPENSERS



PUMPS



METERS



NOZZLE METERS



NOZZLES

PIUSIBOX CAR SUCTION

FEATURES

- IDEAL TO EMPTY VEHICLE TANKS
- IT AVOIDS THE TANK OVERFILLING
- SUZZARABLUE DIAPHRAGM PUMP
- EASY TO HANDLE

The PIUSI BOX Car Suction is the perfect solution for those who need to drain an AdBlue® vehicle tank before servicing. It comes with a portable box that contains all the required equipment.

PERFORMANCE

UP TO

34 L/MIN

FLOW RATE

AC
VOLTAGE

POWER

MAX

2M

BOUND

HOSE LENGTH



PIUSIBOX CAR SUCTION



PACKAGING

CODE	WEIGHT		PACKAGING		
	KG	LBS	MM	INCH	PCS/BOX
FOO201R20	11,5	25,3	650X400X450	25,6X15,7X17,7	1



FILTRATION



FLUID MONITORING



HOSE REELS



ACCESSORIES



MERCHANDISE



AIR



ANTIFREEZE



AdBlue®



BIODIESEL



DIESEL



FOOD



GASOLINE



GREASE



KEROSENE



OIL



WATER



WINDSCREEN

FUNCTIONING

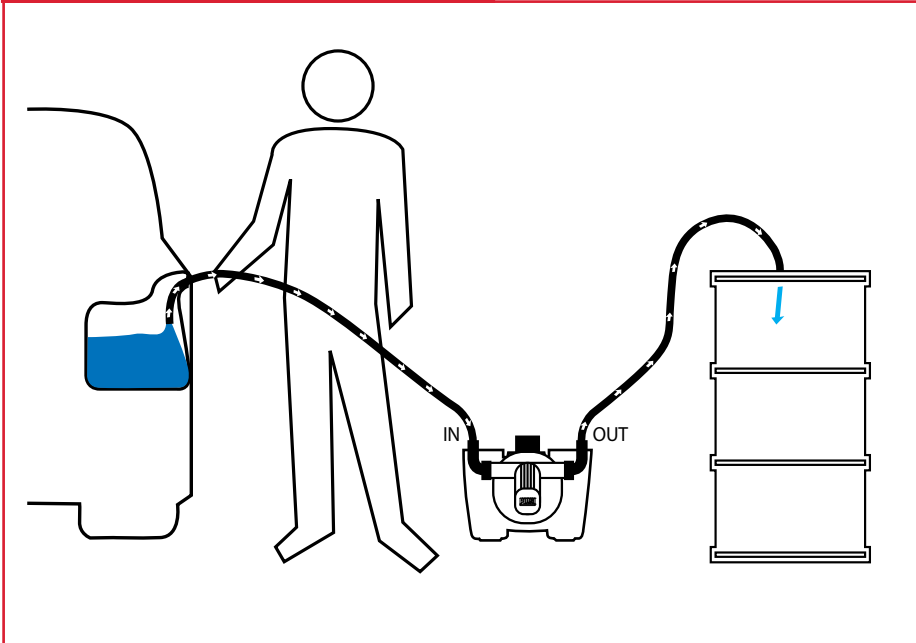

IN THE BOX

- SUZZARABLU PUMPS
- SUCTION / DELIVERY HOSE
- INSTRUCTION MANUAL

DETAILS



SUZZARABLU PUMP AC



ON/OFF SWITCH



HANDLE

DIMENSIONS

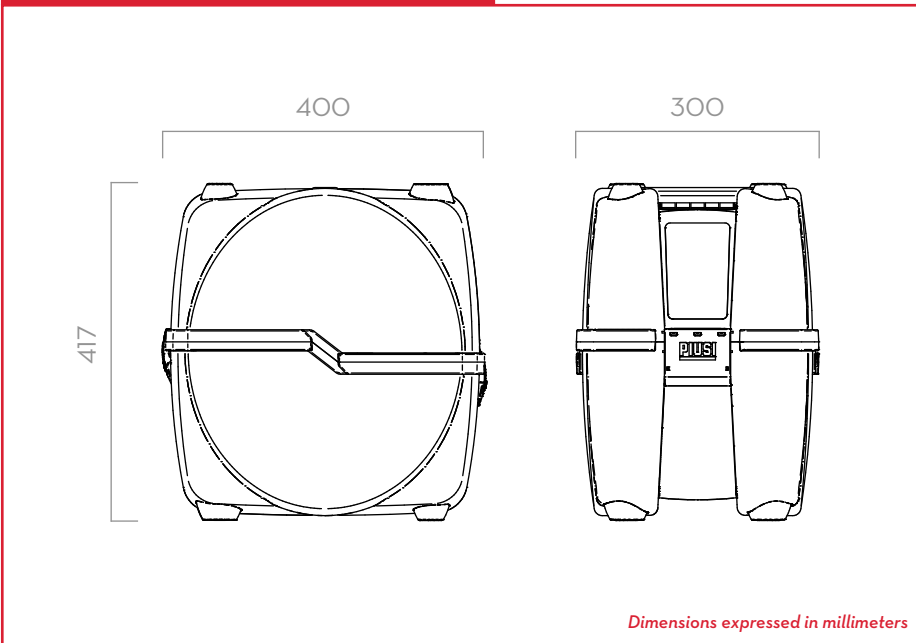

Dimensions expressed in millimeters

MATERIALS

- BODY: POLIPROPYLENE
- DIAPHRAGM: POLIPROPYLENE

TECHNICAL DATA

CODE	DESCRIPTION	FLUIDS TYPE	FLOW-RATE		VOLTAGE			RPM	DUTY CYCLE		CABLE	SUCTION HOSE	DELIVERY HOSE
			L/MIN	GPM	AC V/HZ	DC VOLT	POWER WATT		AMP. MAX.	RPM		MIN	12 MM Ø
FOO201R20	PIUSIBOX CAR SUCTION ADBLUE		34	9	230/50		400	1,95	1450	20	YES	2	2 M

PIUSIBOX CAR SUCTION