



DISPENSERS



PUMPS



METERS



NOZZLE



FILTRATION



FLUID MONITORING

ST

FEATURES

- **RADY TO USE**
- **EASY TO INSTALL**
- **STURDY STRUCTURE**
- **COMPACT DEISGN**
- **AVAILABLE WITH DIFFERENT PUMPS**

The PIUSI ST is a versatile and compact diesel transfer station that can be used to fill mobile tanks or interact with distribution units. It is fitted with check valve, filter, nozzle and 4mt delivery hose. Its sturdy structure makes this dispenser suitable to be used in the harshest environments. It can be integrated with a protective metal box and water separating filter.

PERFORMANCE

UP TO

90 L/MIN

FLOW-RATE

AC/DC

VOLTAGE

POWER

4MT

LENGTH

DELIVERY HOSE

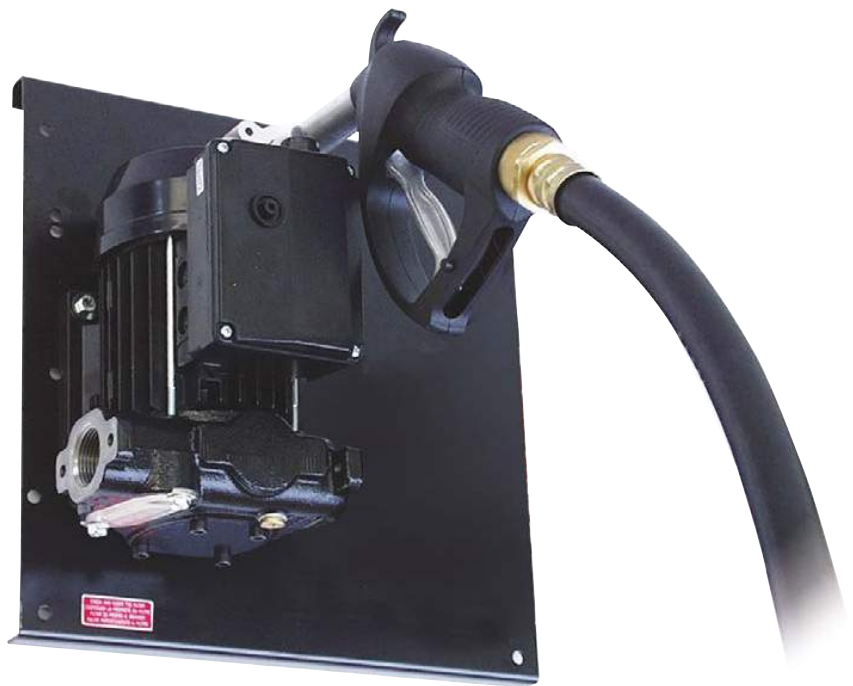

ST



PACKAGING

CODE	WEIGHT		PACKAGING		
	KG	LBS	MM	INCH	PCS/BOX
000266P00	16	35	357X357X275	14,1X14,1X10,8	1
000286P00	16	35	357X357X275	14,1X14,1X10,8	1
000266P20	21	46	357X357X275	14,1X14,1X10,8	1
000214000	21	46	357X357X275	14,2X14,2X11,8	1
000216000	23	50	480X370X265	18,9X14,6X10,4	1
000252000	23	50	480X370X265	18,9X14,6X10,4	1
000248000	20	44	357X357X275	14,1X14,1X10,8	1
FO021000B	10	22	357X357X275	14,1X14,1X10,8	1
FO021100B	10	22	357X357X275	14,1X14,1X10,8	1
FO0340080	19	42	357X357X275	14,1X14,1X10,8	1



HOSE REELS



ACCESSORIES



MERCHANDISE

PIUSI

AIR



ANTIFREEZE



AdBlue®



BIODIESEL



DIESEL



FOOD



GASOLINE



GREASE



KEROSENE



OIL



WATER



WINDSCREEN

AVAILABLE WITH DIFFERENT PUMPS

AC PUMP - PANTHER



AC PUMP - E80



AC PUMP - E120



AC PUMP - VISCOMAT VANE



DC PUMP - BP3000



DC PUMP - PANTHER DC

IN THE BOX

- ST UNIT
- DELIVERY HOSE
- NOZZLE
- NOZZLE HOLDER
- INSTRUCTION MANUAL

DETAILS

MANUAL NOZZLE (pag. 122)

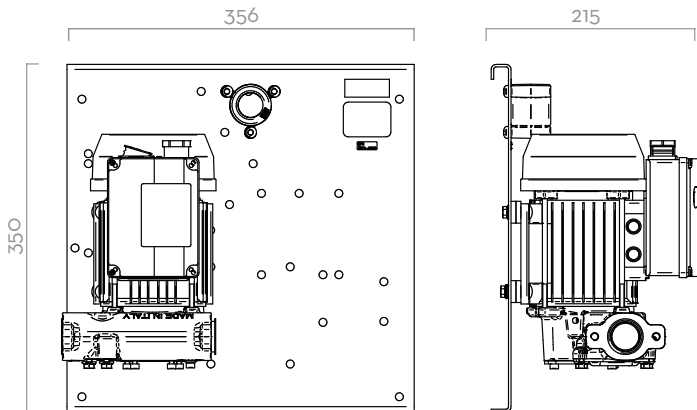

AUTOMATIC NOZZLE (pag. 118)

DIMENSIONS

Dimensions expressed in millimeters

COMPONENTS

- **PUMP:**
 - PANTHER AC PAG. 64
 - E80/E120 PAG. 68
 - VISCOMAT VANE PAG. 66
 - BP3000 PAG. 74
 - PANTHER DC PAG. 78
- **NOZZLE:**
 - MANUAL NOZZLE PAG. 122
 - AUTOMATIC NOZZLE PAG. 118

TECHNICAL DATA

CODE	DESCRIPTION	FLUIDS TYPE	FLOW-RATE		VOLTAGE			METER	NOZZLE	FILTER	DELIVERY HOSE		INLET
			L/MIN	GPM	AC V./HZ DC VOLT	POWER WATT	AMP. MAX.				TYPE	LENGTH	
OOO266POO	ST PANTHER 56	D	56	15	230/50	350	3	NO	MAN.	NO	4M	3/4"	1"
OOO286POO	ST PANTHER 56 A60	D	56	15	230/50	350	3	NO	AUT.	NO	4M	3/4"	1"
OOO266P2O	ST PANTHER 72/M	D	72	19	230/50	500	4,2	NO	MAN.	NO	4M	3/4"	1"
OOO214OOO	ST E 80	D	80	21	230/50	700	3,5	NO	MAN.	NO	4M	1"	1"
OOO216OOO	ST E 120	D	90	24	230/50	1150	5,7	NO	MAN.	NO	4M	1"	1"
OOO252OOO	ST E 120 A120	D	90	24	230/50	1150	5,7	NO	AUT.	NO	4M	1"	1"
OOO248OOO	ST VISCOMAT 70 (RAPSOIL)	B	30	8	230/50	950	4,6	NO	MAN.	NO	4M	1"	1"
FOO210OOB	ST BYPASS 3000 12V	D	42	11	12	260	22	NO	MAN.	NO	4M	3/4"	1"
FOO211OOB	ST BYPASS 3000 24V	D	42	11	24	300	12	NO	MAN.	NO	4M	3/4"	1"
FOO340O8O	ST PANTHER DC 12V	D	56	15	12	420	35	NO	MAN.	NO	4M	3/4"	1"

THE UNIT CAN ALSO BE SUPPLIED FOR OPERATING UNDER DIFFERENT VOLTAGES AND WITHOUT METER.

ST

ST

41