

TECHNICAL SPECIFICATION SHEET

<u>Product Reference</u>	Drum Pump NX 200
Customer Reference:	tba
Drawing:	(see over)
Dose:	380ml approx (full cycle)
Closure:	2" Trisure (others available)
No. of strokes to discharge:	6-7
Discharge pressure:	Low pressure – typical 4/5 kgs (subject to liquid rheology)
Colour:	white
Dip tube**:	fixed

General Comments:

Low pressure drum pump – suitable for most large drums approx 200 litre capacity

Anti drip nozzle

Various attachment options

High viscosity liquid dispense option

General chemical compatibility - good

Do not use to dispense petroleum products

NX200 Drum Pump

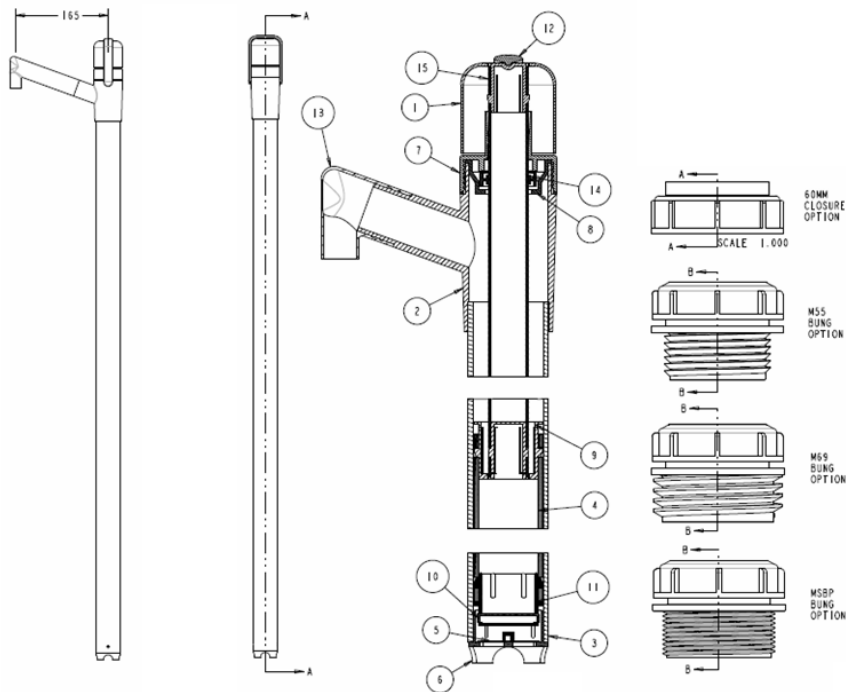

The NX Drum Pump Parts List

No	Title of Part	Part no
2	Drum Pump Actuator	SNDP0025-PT
3	Drum Pump Body	SNDP0002-PT
4	Drum Pump Body Tube	SNDP0003-PT
5	Drum Pump Bottom Extrusion	SNDP0011-PT
6	Drum Pump Main Collar	SNDP0007-PT
7	Drum Pump Plunger Collar Seal	SNDP0029-PT
8	Drum Pump Plunger Extrusion Connector	SNDP0015-PT
9	Drum Pump Safety Strap	SNDP0024-PT
10	Drum Pump Short Outlet	SNDP0016-PT
11	Drum Pump O-ring Seal	SNDP0030-PT
12	Drum Pump Top Extrusion	SNDP0012-PT
13	One Piece Foot Flap Valve	SNDP0027-PT
14	One Piece Plunger Flap Valve	SNDP0028-PT